**SEISMIC DAMAGE CONTROL WITH
PASSIVE ENERGY DEVICES: A CASE STUDY**

by

**Robert J. McNamara, SE
McNamara/Salvia, Inc.
Consulting Structural Engineers
One International Place
Boston, MA 02110**

This paper presents a theoretical case study of the effectiveness of supplemental passive damping devices in reducing structural response during seismic excitation. A six-story special moment resistant reinforced concrete frame is studied with and without the aid of supplemental dampers. Response predictions are presented for each case. Physical design requirements are presented for a new facility implementing the supplemental damping system to reduce seismic damage and improve the post-earthquake operational capability of the facility.

INTRODUCTION

Presently there exists considerable interest in predicting the damage of ordinary structures experiencing seismic events. Reliability of predicting the seismic damage is being recognized as an important design consideration for structures such as hospitals, police and fire stations, etc. Post earthquake operational capabilities of these facilities is an essential design consideration.

The Structural Engineers Association of California (SEAOC) defines the overall philosophy related to seismic design in their "Recommended Lateral Force Requirements and Commentary" [1] which states the following:

Structures designed in conformation with these recommendation should, in general, be able to:

1. Resist a minor level of ground motion without damage;
2. Resist a moderate level earthquake ground motion without structural damage;
3. Resist a major level of earthquake ground motion having an intensity equal to the strongest either experienced or forecast for the building site without collapse, but possibly with some structural as well as non-structural damage.

Most modern building codes and recommended guidelines such as the Uniform Building Code (UBC) [2] and National Earthquake Hazards Reduction Program (NEHRP) [3] adopt a similar philosophy in developing their seismic design requirements. Post earthquake operational capability is usually addressed by increasing the code prescribed forces. Damage control is not explicitly addressed in most codes.

SEISMIC DAMAGE MITIGATION

Implicit with the building code design philosophy referenced above is an unpredictable amount of inelastic action and therefore structural damage. The reduction of the "elastic" force level to the code design force level is usually accomplished by the use of response reduction factors such as the " R_w " factor currently used in the UBC. Figure 1 indicates the magnitude of the response modification for a special moment resistant space frame (SMRF) where $R_w = 12$. The shaded region of the load-deformation curve represents the seismic energy dissipated by inelastic behavior of the various members in the structure subjected to a major seismic event. This shaded region also represents structural damage, albeit analytically unpredictable. Considering the uncertainty associated with seismic ground intensities and motion predictions for a given site, the damage associated with the implied inelastic action may or may not be repairable. The general consensus among Structural Designers is that the structure should not collapse during a major earthquake (as required by the code) but that the amount of damage the structure will sustain is very unpredictable. Heavy reliance is placed on ductile seismic detailing and proper construction methods to insure the dissipation of energy and the ultimate integrity of the structure.

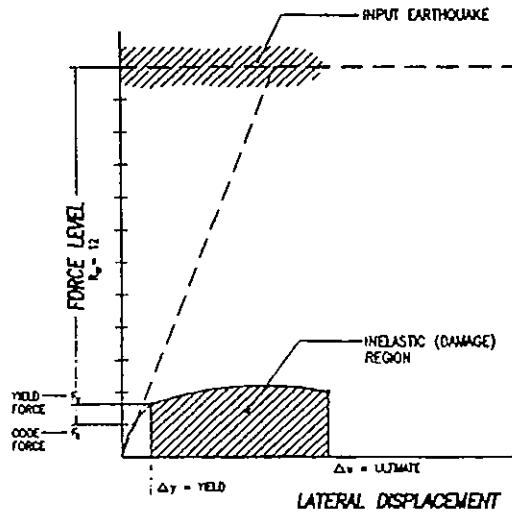

FIGURE 1
INDICATES THE MAGNITUDE OF THE RESPONSE MODIFICATION
FOR SPECIAL MOMENT RESISTANT SPACE FRAME (SMRF) WHERE $R_w = 12$

In current practice, seismic damage control is approached by one or a combination of the following methods:

1. Importance Factor: Increase code prescribed forces through the use of an importance factor (I).
2. Deflection Control: Limit inter-story deflections under code prescribed forces.
3. Ductile Detailing: Special seismic detailing to avoid brittle and catastrophic failures.
4. Seismic Isolation and Dampening: Base isolation systems and Supplemental Passive Energy Devices.

A brief discussion of each of the above methodologies follows.

Importance Factor: Most building codes prescribe the use of an Importance Factor to amplify the design forces for essential facilities which must operate in a post-earthquake scenario; examples are hospitals, police stations, fire stations etc. The UBC prescribes a maximum importance factor of 1.25. Studies of the inelastic behavior of ductile structural systems under the action of various ground motions have shown that this approach does little to improve the structure's performance or control damage. To illustrate the ineffectiveness of this method, a model frame for a proposed facility with damage control requirements was developed. Lateral strengths for a special moment resistant frame as required by 1.0 x UBC, 1.25 x UBC and 1.5 x UBC were studied using the El Centro accelogram record with a peak ground motion of .4g. This record is used as a Design Basis Earthquake (DBE) and is selected for illustrative purposes only. The model frame was analyzed

using the Drain-2DX program to study the nonlinear response. Figure 2a indicates that for each level of increased system strength, the structure undergoes significant inelastic deformations for the same input ground motion. Figure 2b indicates similarities in the roof displacements for each strength level experiencing the same input ground motion. The input earthquake brings each structure into the yield range independent of its design strength level. In fact, the base shear that the structure experiences increases with the increased strength level for the same input earthquake. If either the number of yield events or the lateral displacement is used as a measure of damage, increasing the design force (and hence ultimate strength level) level is not an effective method for improving structural performance. Most researchers now agree that the Importance Factor approach is not an appropriate method for positive damage control. The problem with this method lies with the significant reduction in seismic design force taken with the system modification factor “ R_w .” Multiplying the reduced design forces by 1.25 or 1.5 has little effect on improving overall behavior or damage control. Figure 2a reinforces the fact that each strength level provided is brought to yield by the same input ground motion.

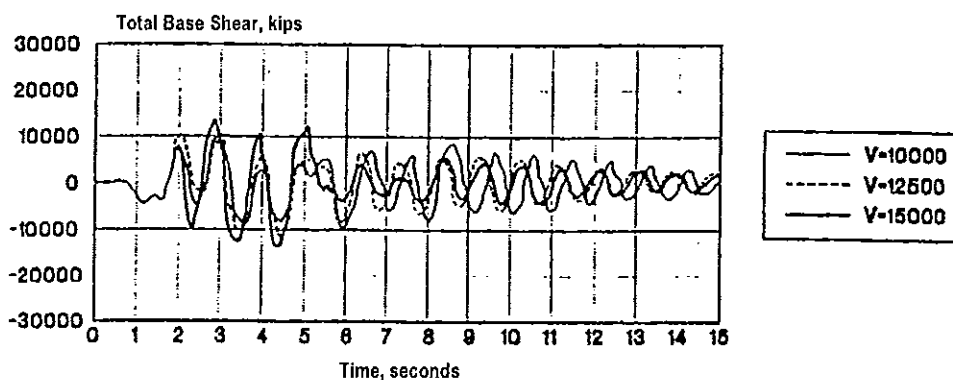

FIGURE 2A
EFFECT OF SYSTEM STRENGTH ON BASE SHEAR RESPONSE

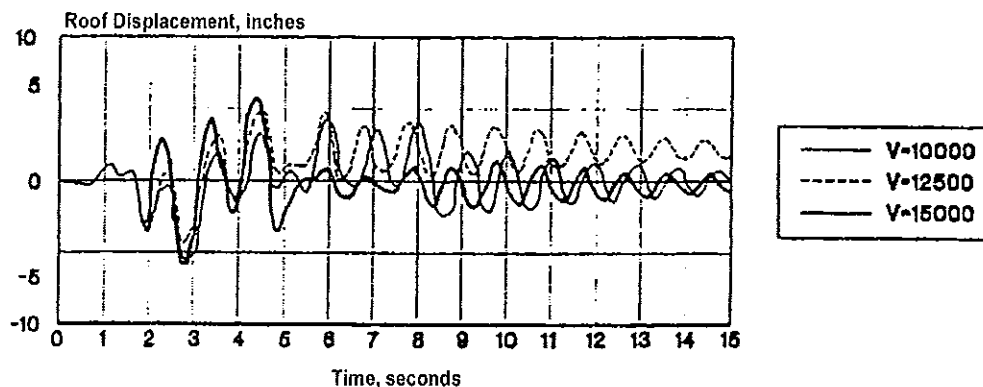

FIGURE 2B
EFFECT OF SYSTEM STRENGTH ON DISPLACEMENT

Deflection Control: Controlling damage by limiting the lateral inter-story deflection appears to be a more rational approach than the Importance Factor method, but problems still arise attempting to compute realistic deflections from code prescribed forces. Factors have been developed whereby the computed elastic deflection is amplified by a factor to account for actual (inelastic) versus assumed elastic behavior. This approach is approximate at best and recent research indicates that the $\frac{3}{8} R_w$ modification factor in the current UBC Code is inappropriate for deflection amplification and a more conservative factor of .6 or $1.0 R_w$ should be used for a SMRF [4].

Ductile Detailing: Seismic detailing, when applied to very stiff structures such as concrete and masonry shear walls, is necessary to prevent brittle or catastrophic (explosive) failures. When applied to structures such as SMRF's, it is necessary so that the assumed inelastic deformations can indeed occur without other more brittle failure modes occurring. This detailing should not be considered a "damage control" method in that with proper ductile detailing large inelastic distortions (and therefore structural damage) still occur. The special detailing requirements are required to insure that the inelastic deformations do take place so that the seismic energy will be dissipated.

It is the writer's opinion that none of the above measures are appropriate for reliable damage control and that the future of seismic damage control lies with methods such as Base Isolation Systems or adding Supplementary Damping to the structure. Only by designing damping systems directly, similar to the way the gravity or lateral load system is designed, can effective damage control be achieved.

Base Isolation Systems have been codified under the UBC and this system is an accepted positive method for limiting the forces to which a structure will be subjected. In general the system can be very effective in reducing the seismic input to the structure under certain frequency ranges. The implementation of base isolation systems can be quite costly and the method seems to be applicable to a limited class of structures. Significant research and development has occurred in the past decade and the development of various isolation devices continues [5].

The application of Supplemental Damping Systems for damage control has seen many applications outside of the United States in the past 15-20 years. New Zealand, Canada and Japan all have buildings employing dampers of various types to dissipate seismic energy. Currently most US activity with supplemental damping systems has been related to seismic retrofits of existing structures. However, code requirements for the construction of buildings with passive energy dissipation systems are currently being developed by the Structural Engineers Association of California. The requirements have been published as "Tentative General Requirements for the Design and Construction of Structures Incorporating Discrete Passive Energy Dissipation Devices" [6]. Currently a commentary is being written and the completed document will be submitted to the International Conference of Building Officials (ICBO) for their review and eventual inclusion in the UBC. Considerable interest in the application of passive energy devices is evidenced with the recent seminar sponsored by the Applied Technology Council (ATC) [5] and the publication of a theme issue of Earthquake Spectra [7] devoted entirely to this subject.

Passive energy devices (PED's) designed and installed in accordance with the requirements of the "Tentative Recommendations" can provide cost effective, positive damage control for structures during major earthquakes. The design concept prescribed in the "Tentative Recommendations" is

to prevent the structure from undergoing inelastic deformations for a Design Basis Earthquake and to have minor inelasticity during a major earthquake. The passive devices are designed to dissipate a large portion of the earthquake input energy which ordinarily the structure would dissipate through inelastic deformations. Estimated “effective” damping ranges of 15 to 20% of critical are not uncommon. The nature of the energy dissipating system can take many forms as outlined in the “Tentative Recommendations” document.

Application of a PED system to an actual structure is presented below in the form of a case study to access its effectiveness in seismic response reduction.

The PED system proposed is composed of fluid damper elements in the form of diagonal bracing. The fluid damper PED was chosen because of its insensitivity to temperature along with its ability to provide very high levels of damping and load capacity for each damper installed. With the high load capacity, a minimal number of bracing locations are required thus minimizing the impact of the PED system on the architectural layout.

CASE STUDY WITH PED

A schematic layout of the actual structure and proposed locations for PED's is shown in Figure 3. The lateral force resisting system is a perimeter reinforced concrete SMRF. This investigation was limited to the preliminary assessment of a PED systems effectiveness in reducing seismic response. The investigation concentrated on analyzing the structure in the transverse direction only and designing the PED to prevent the structure from yielding under the DBE. The study focused on the number of yield excursions various members experienced during a seismic event as a simple means of measuring damage. Behavior of the system beyond initial yield was not investigated.

A representative SMRF was designed in accordance with the UBC using $R_w = 12$ and ultimate strengths proportioned according to current design practice. The SMRF with and without the PED System was subjected to various ground motions. Two design basis earthquakes (DBE) with a peak ground acceleration of .4g, and a maximum credible earthquake (MCE) with a peak acceleration of .6g were used as input motions. The El Centro and Taft records were used for the DBE and the Taft record was used for the MCE. More specific seismic site information was not available at the time of the study, but will be required for the design to be implemented in the building. At that time a family of ground motions will be generated to design the PED as required by the “Tentative Recommendations.”

Various vertical PED configurations were investigated, and the system shown in Figure 4 was found to be the most cost effective to produce the response reduction desired. The frames were analyzed using DRAIN-2DX, a program capable of capturing the non-linear behavior of the SMRF and also modeling the fluid dampers as viscous elements. Figure 5 shows the DRAIN-2DX model analyzed. A type O2 element was used to model the non-linear aspects of the column and beam elements since initial yield excursions were of primary interest in this investigation.

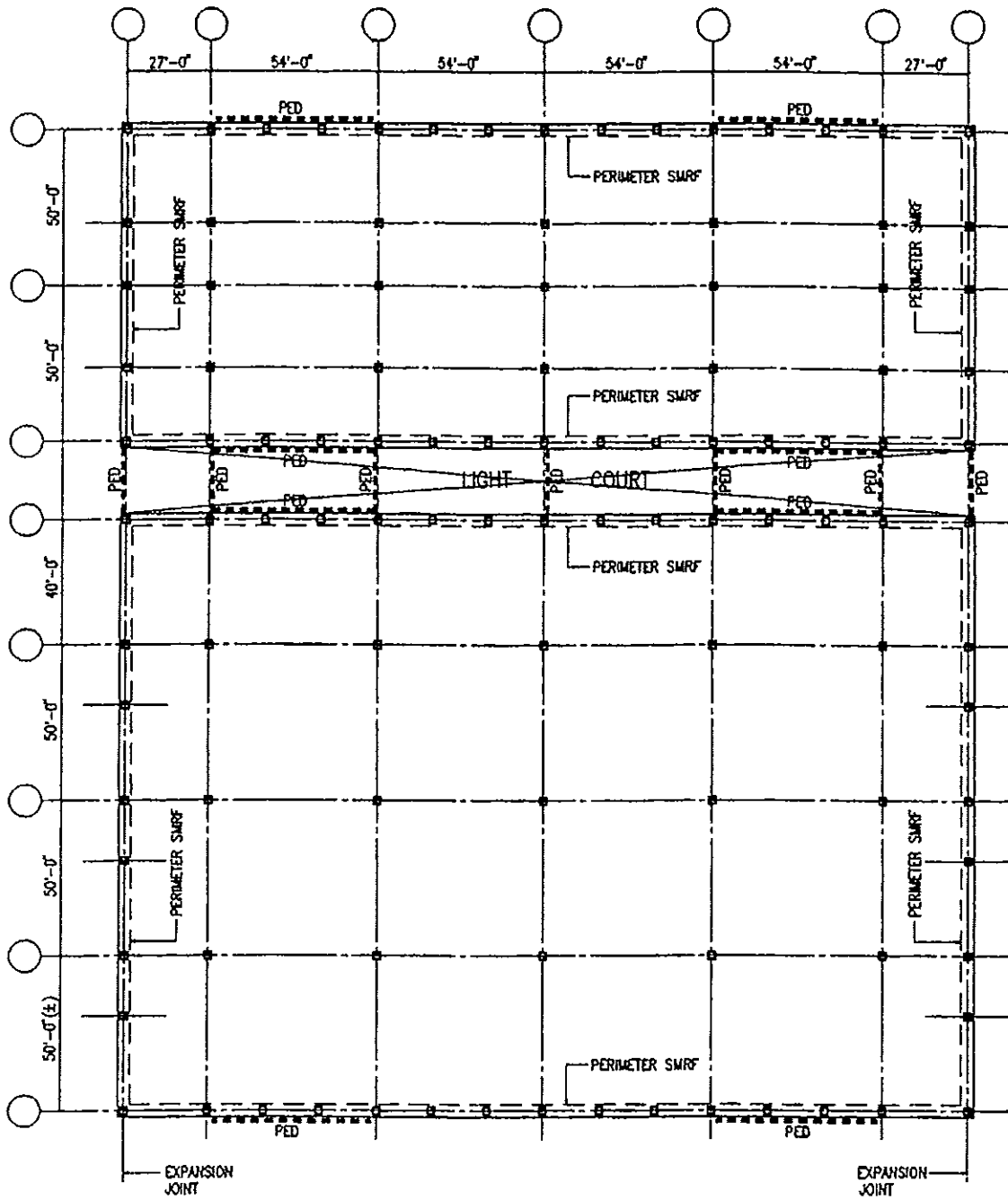
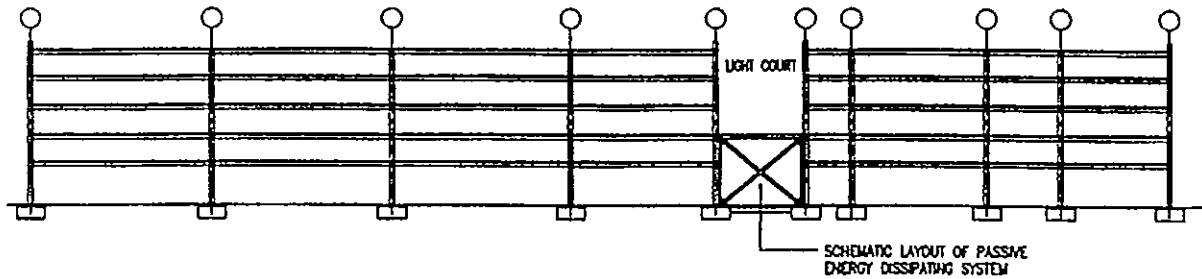
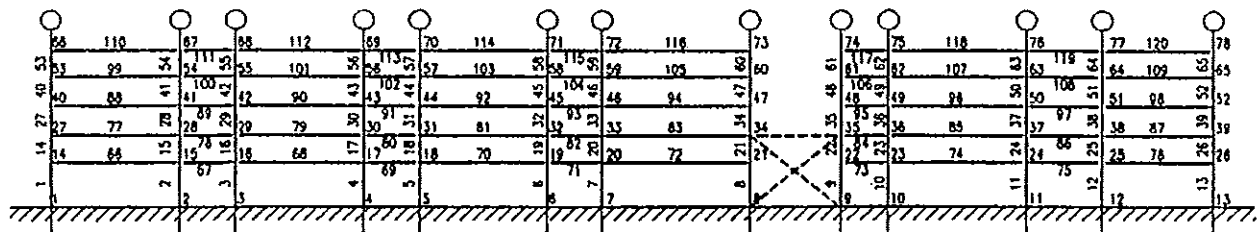

FIGURE 3
A SCHEMATIC LAYOUT OF THE ACTUAL STRUCTURE AND
PROPOSED LOCATIONS FOR PASSIVE ENERGY DEVICES



**FIGURE 4
TRANSVERSE SECTION**



**FIGURE 5
PERIMETER SMRF DRAIN 2DX MODEL**

Figures 6 and 7 indicate the effectiveness of the PED in eliminating girder and column yielding under the DBE. The figures show the structure without the PED experiencing numerous yield excursions and no yield events for the structure with the dampers. Figure 8 indicates the number of yield events for the assumed MCE. In this analysis significant yielding occurs in both the columns and girders of the undamped structure whereas the structure with PED experiences very few yield events.

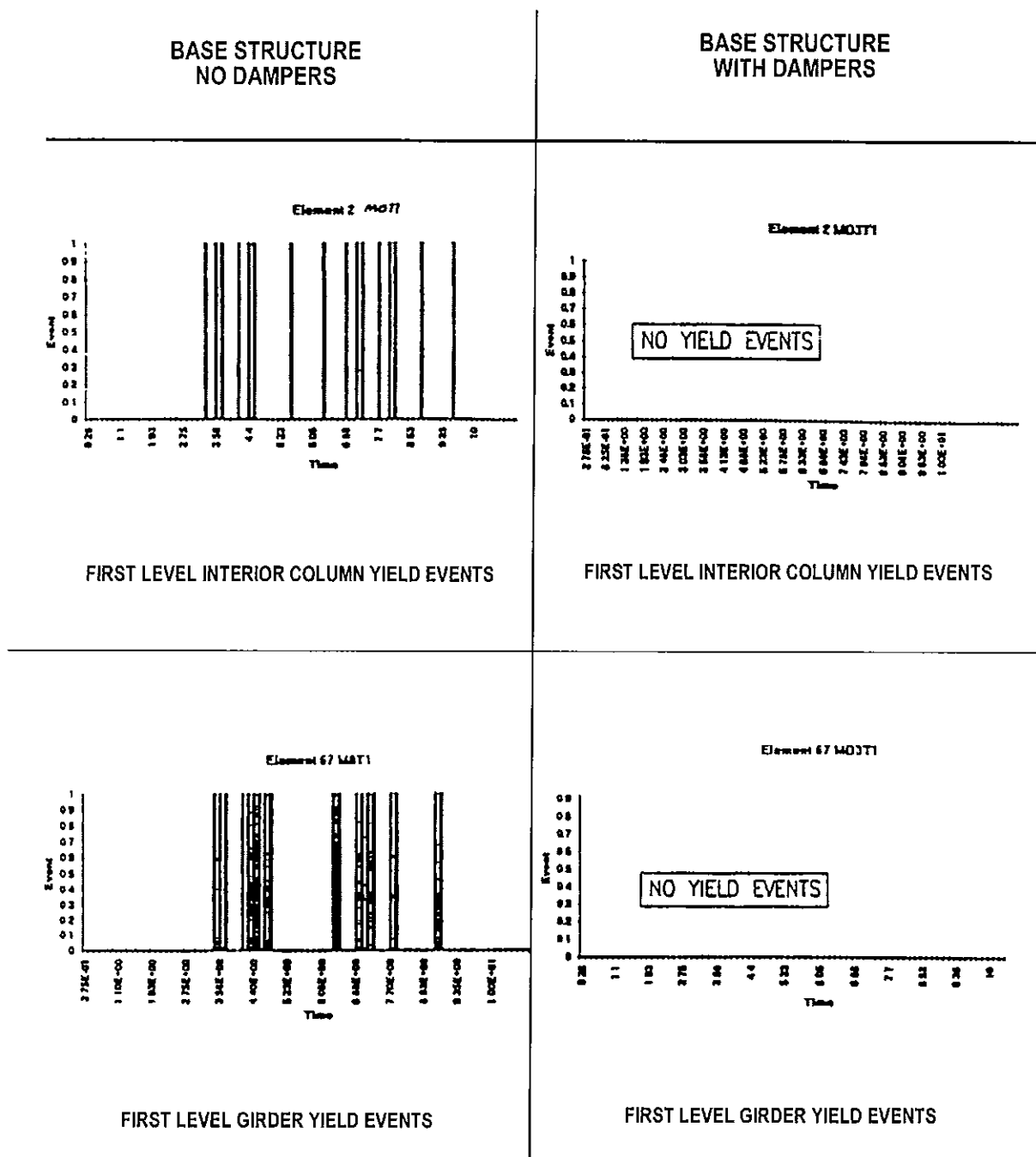

FIGURE 6
EARTHQUAKE INPUT - DBE - TAFT RECORD .4G

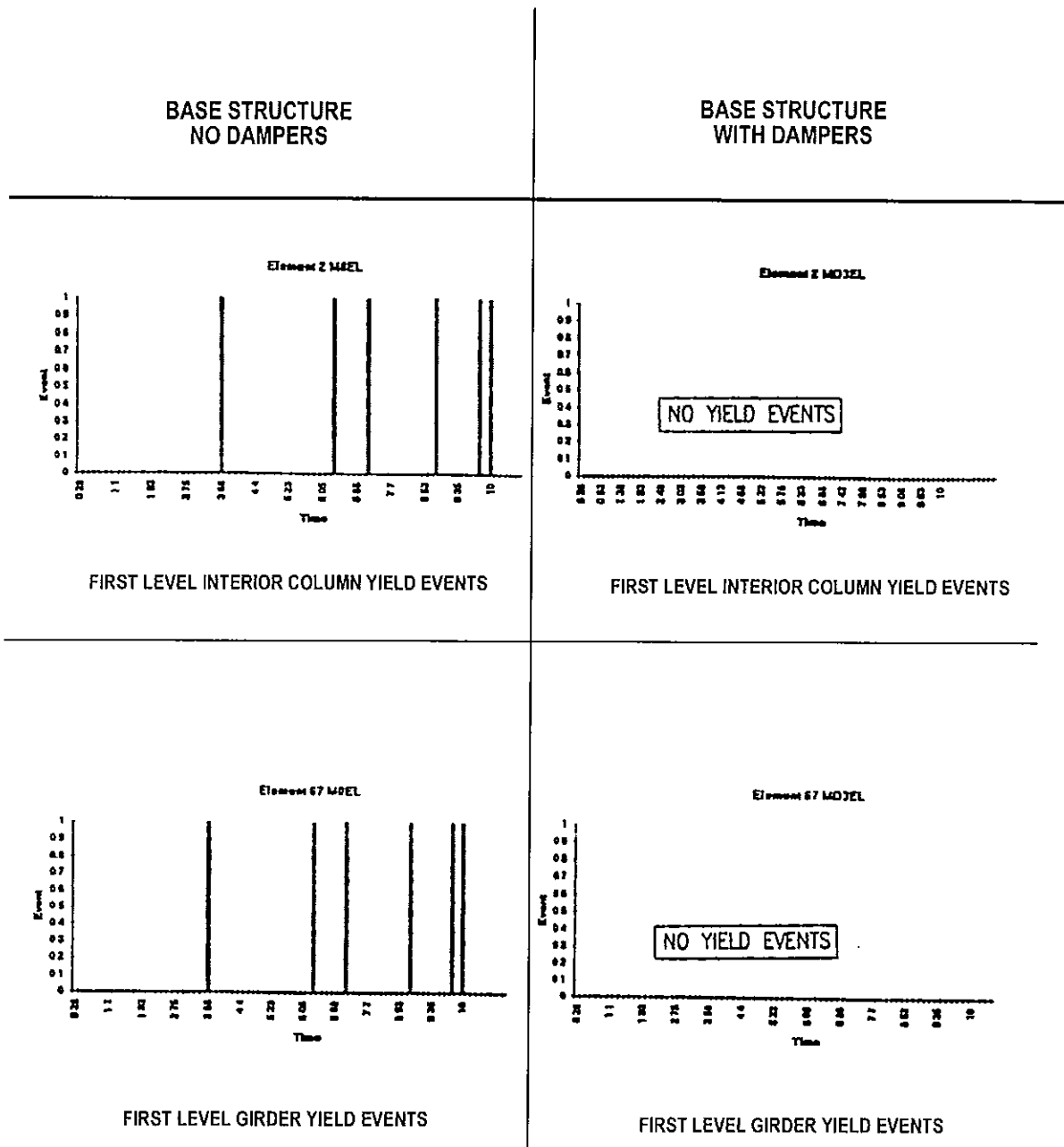

FIGURE 7
EARTHQUAKE INPUT - DBE - EL CENTRO .4G

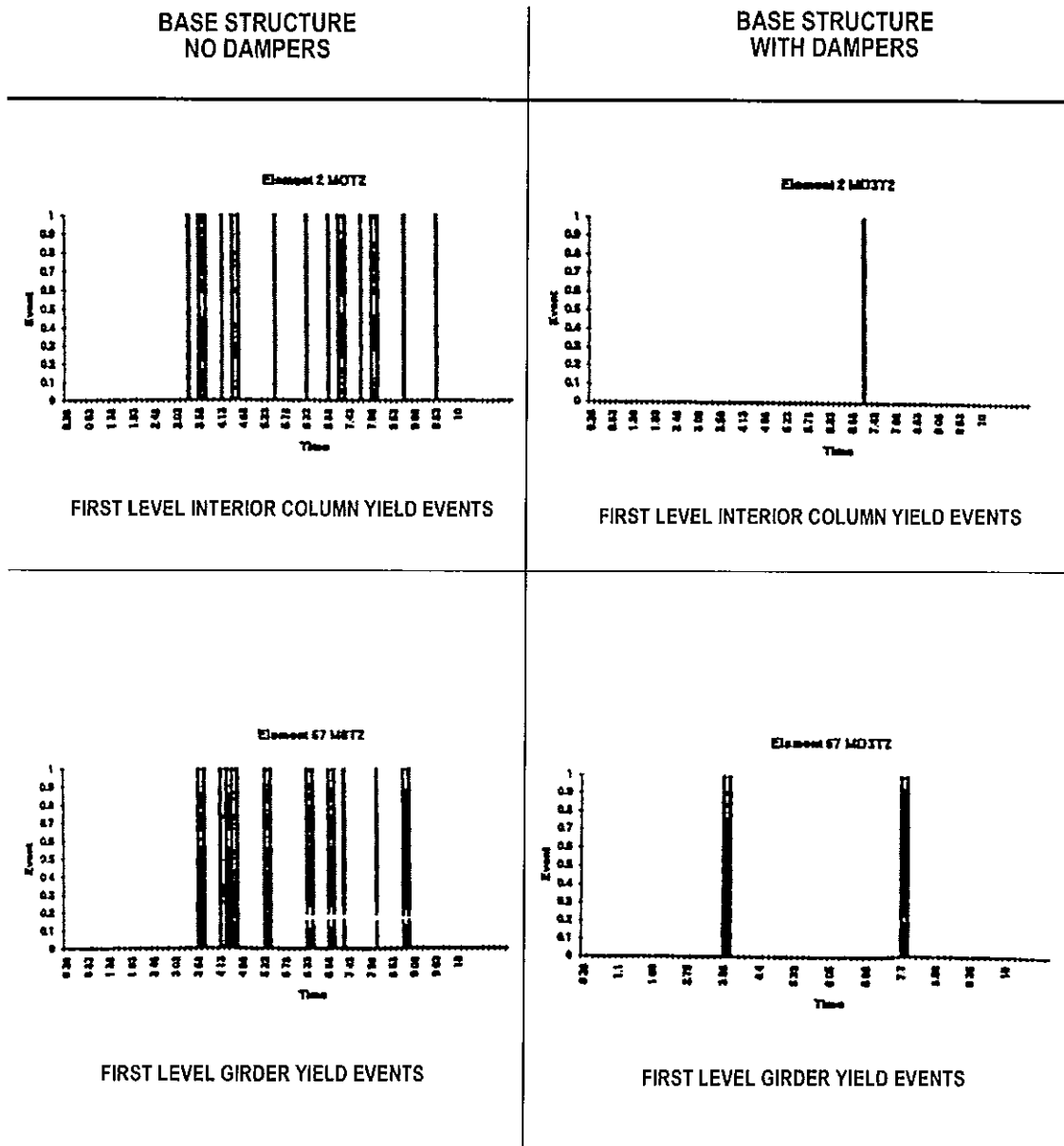

FIGURE 8
EARTHQUAKE INPUT - MCE - TAFT RECORD .6G

Figures 9a and 9b indicate the top floor displacement with and without dampers for the Taft and El Centro DBE respectively. The response reduction as a result of the PED is clearly evident from these plots. It is of interest to note that the predicted roof displacement of the SMRF without a PED system far exceeds the code estimated deflections.

ROOF DISPLACEMENT

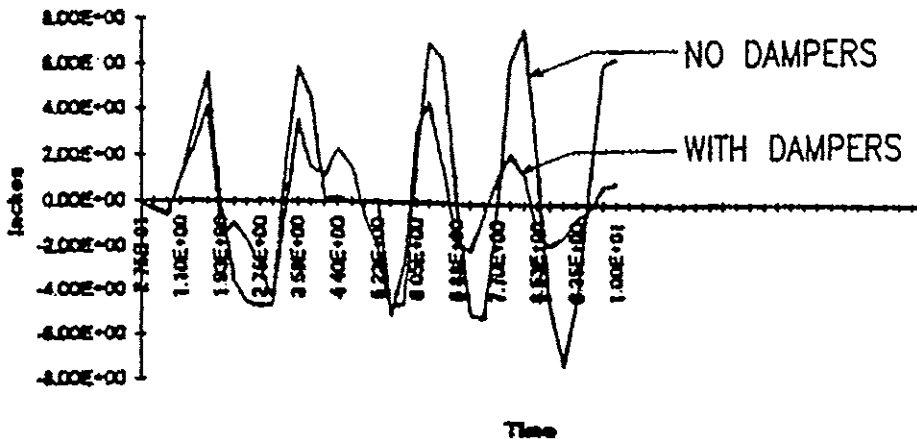

FIGURE 9A
EARTHQUAKE INPUT - DBE - EL CENTRO .4G

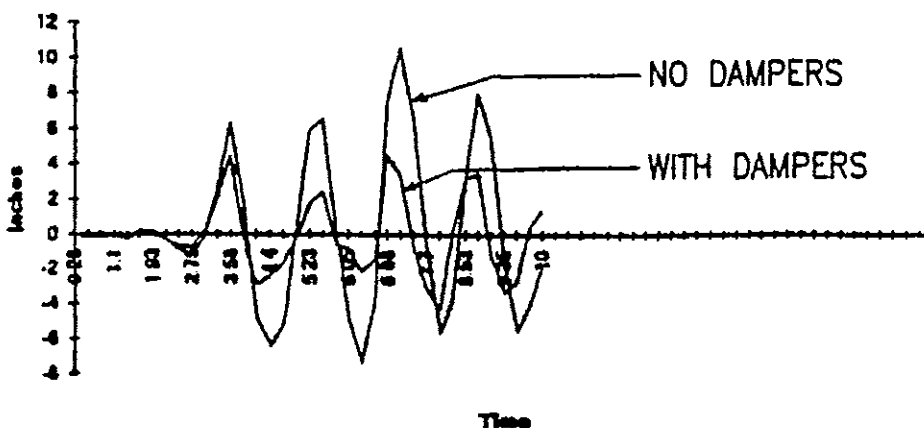

FIGURE 9B
EARTHQUAKE INPUT - DBE - TAFT RECORD .4G

Figures 10a and 10b graphically demonstrate the fundamental modification of structural behavior by the inclusion of the PED System. Figure 10a shows the distribution of input energy thru time for the structure without PED. As can be seen in the graph, a significant amount of energy is dissipated by the inelastic action of the columns and girders of the SMRF. Figure 10b shows the change in energy dissipation within the system with the majority of energy being dissipated by the PED system and small amount by inelastic action.

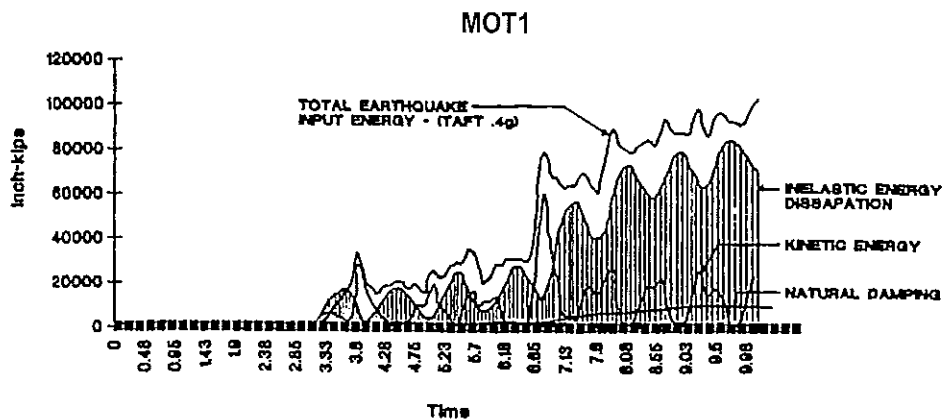

FIGURE 10A
BASE STRUCTURE - NO DAMPERS

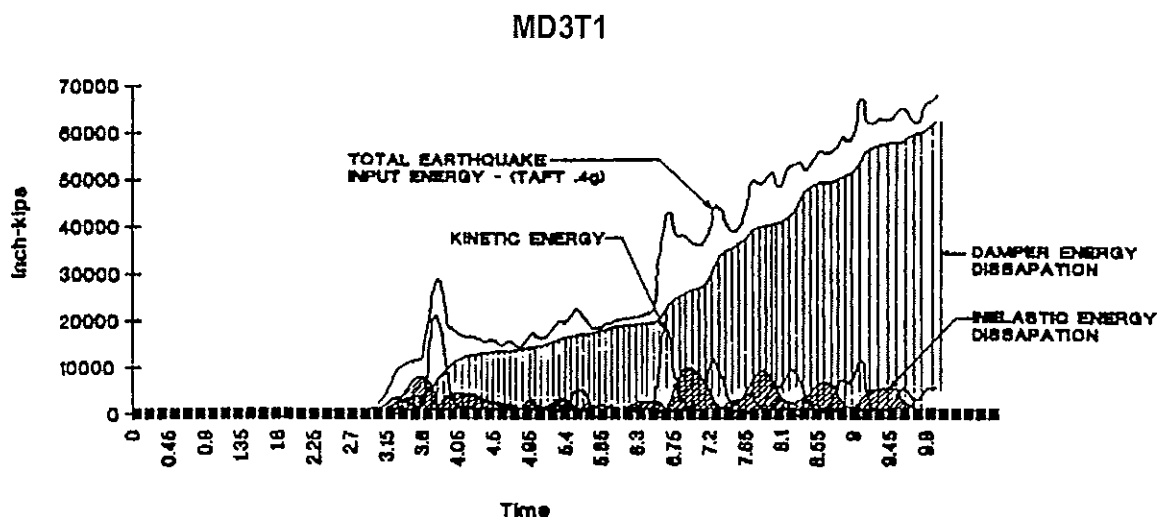

FIGURE 10B
BASE STRUCTURE - WITH DAMPERS

The energy distribution plots clearly indicate the basic change in behavior of the two systems under the action of seismic motions. The base SMRF dissipates much of the input energy through hysteretic (inelastic) action. As mentioned earlier, inelastic dissipation represents structural damage, is unpredictable as to its extent and relies on a special detailing to insure proper behavior. The structure with the PED system dissipates most of the input energy through the action of the PED system. Since the PED system is designed directly for energy dissipation it has a much higher reliability in controlling structural damage.

FLUID DAMPER PROPERTIES

Preliminary design centered around providing a PED system which would provide an overall “effective” damping of the combined system in the range of 15 to 20% of critical. PED parameters were then varied and analysis carried out until the response reduction was achieved and control parameters for the actual physical damper could be specified. The investigation indicated for the geometric arrangement shown in Figures 3 and 4 that the required damper force would be 150K with a maximum stroke of plus or minus 2.0 inches and a damping coefficient of 300 K-sec/inch. A typical fluid damper hysteresis plot is shown in Figure 11.

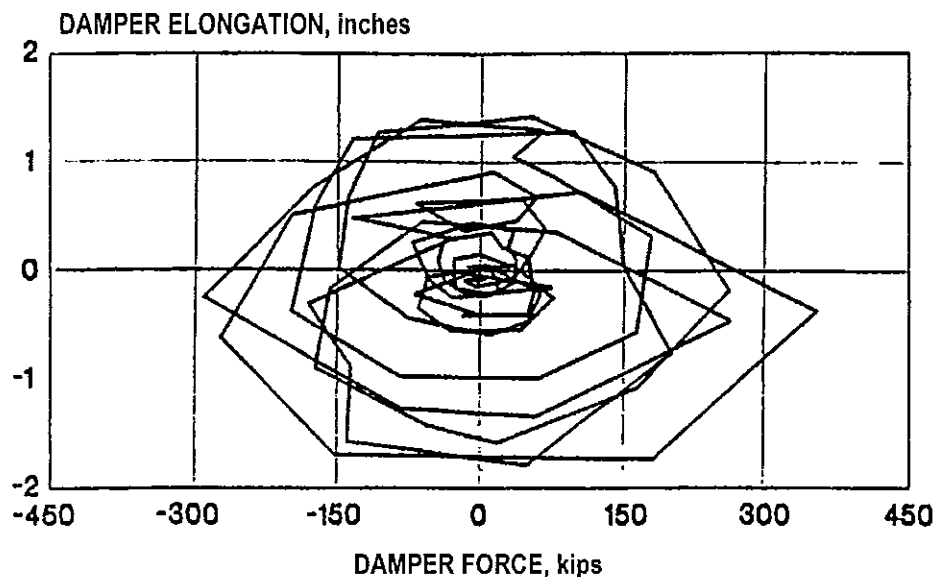
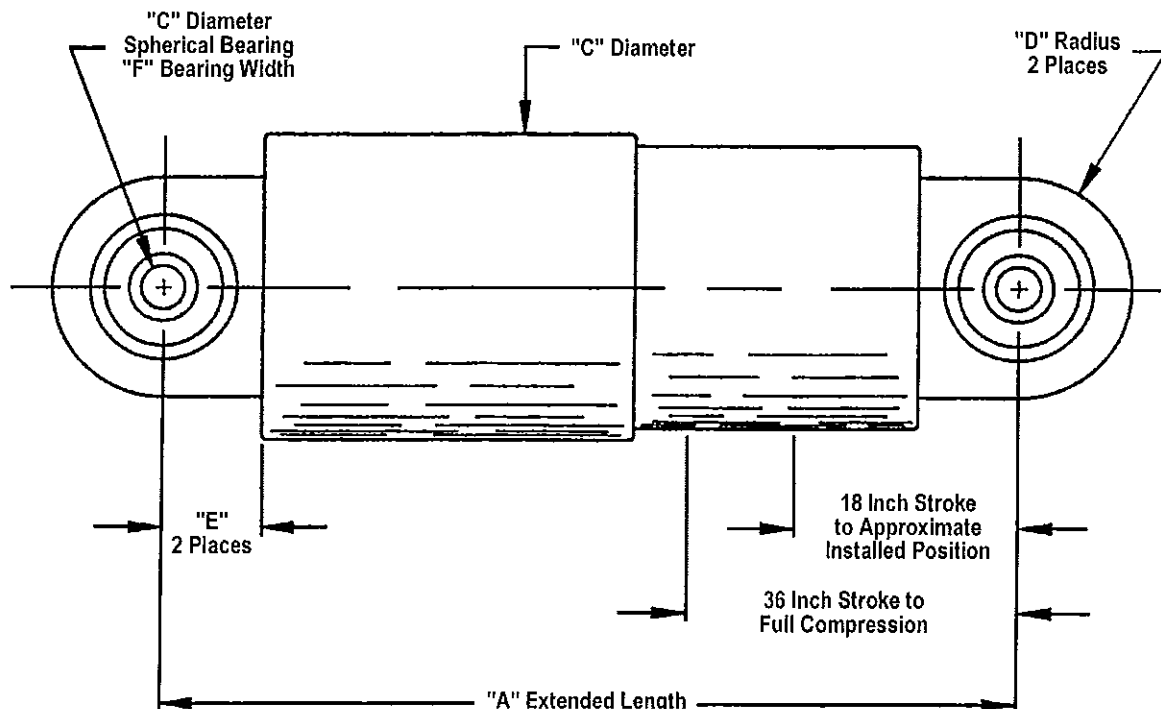

FIGURE 11
DAMPER HYSTERESIS IN INELASTIC STRUCTURE
WITH C = 300 K-SEC/INCH

Manufacturers of fluid dampers indicated that this specification could be easily attained. The damper geometry to achieve the above specification was provided by Taylor Devices of North Tonawanda, New York and is shown in Figure 12. Structural details of actual connections have not been investigated in this study.

The preliminary cost estimates to incorporate the PED system as shown in Figures 3 and 4 would be approximately 1 to 2% of the cost of the facility. This system provides an “effective” damping to the overall structure of approximately 16% of critical.



Part Number	Capacity	"A"	"B"	"C"	"D"	"E"	"F"
67DP-15232-01	100 kip	131	7½	2½	3 ³ / ₁₆	4¾	2 ³ / ₁₆
67DP-15231-01	200 kip	132	9	2¾	3 ⁷ / ₈	5	2 ¹³ / ₃₂
67DP-15229-01	300 kip	138	11½	3	4¼	5¼	2 ⁵ / ₈
67DP-15213-01	600 kip	154 ⁷ / ₈	16	6	7½	10	4¾
67DP-15233-01	1000 kip	166	23	6	9	14¼	4¾

FIGURE 12
HIGH CAPACITY HYDRAULIC DAMPERS FOR BASE
ISOLATED OR EXTERNALLY BRACED STRUCTURES

CONCLUSIONS

The inclusion of Supplemental Passive Energy Devices in the form of fluid dampers proved to be a very cost-effective method for significantly reducing the seismic response of the building investigated. In all of the above preliminary studies, the effectiveness of the PED on response reduction is clearly evident. Preliminary cost estimates indicate that positive damage control can be economically achieved. Although presently there is not a consistent methodology to analyze and measure damage to structures, preventing yield excursions and inelastic action would appear to be a very desirable goal. From the examination of the PED in this case study, the PED system will economically achieve that goal.

ACKNOWLEDGMENTS

The author would like to thank Finley Charney of J.R. Harris Co., Denver, Colorado for his assistance in the validation of the non-linear analyses used in the case study and the preparation of Figures used in the presentation of the results.

REFERENCES

1. "Recommended Lateral Force Requirements and Commentary," Seismology Committee Structural Engineers of California, 1990.
2. "Uniform Building Code," International Conference of Building Officials, Whittier, CA.
3. "National Earthquake Hazards Reduction Program," Federal Emergency Management Association, Washington, D.C.
4. "Displacement Amplification Factor for Seismic Design Provisions," C.M. Uang Proceedings of Structures Congress, 1993, Vol. I.
5. "Seminar on Seismic Isolation, Passive Energy Dissipation and Active Control," Vol. I & II, Applied Technology Council, ATC 17, March, 1993.
6. "Tentative General Requirements for the Design and Construction of Structures Incorporating Discrete Passive Energy Dissipation Devices," Structural Engineers Association of California, 1992.
7. "Passive Energy Dissipation," Journal of the Earthquake Engineering Research Institute, Vol. 9, No. 3, August, 1993.