

TEMPERING Tremors

BY MARK SARKISIAN, S.E., P.E.,
PETER LEE, S.E., P.E.,
LINDSAY HU, P.E., AND
ALVIN TSUI, S.E., P.E.

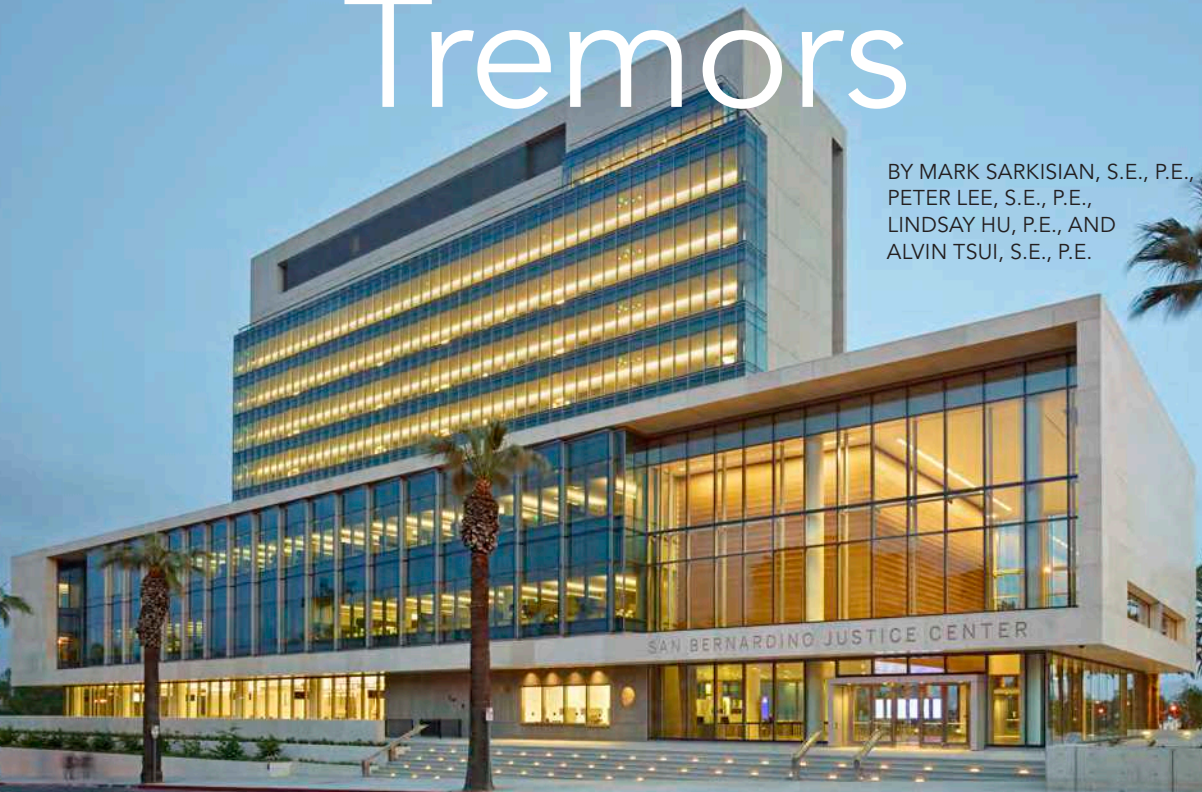

San Bernardino's new courthouse
features a comprehensive seismic design that minimizes life-cycle costs.

SAN BERNARDINO JUSTICE CENTER (SBJC) is the tallest building in San Bernardino County, Calif., and one of the tallest seismically base-isolated buildings in the United States.

Consisting of two building elements—an 11-story courtroom tower and an interconnected, three-story podium—the new 383,745-sq.-ft building contains 35 courtrooms and improves the efficiency of the courts by consolidating functions that had previously been spread throughout the county across 12 different buildings, many of them vulnerable to earthquakes.

In close proximity to known active faults including the San Jacinto, San Andreas and the Cucamonga Faults, the SBJC is located in one of the most active seismic regions in the U.S. It is designed in conformance with the 2006 *Trial Court Facility Standards of the Judicial Council of California* (JCC) to achieve “enhanced” seismic performance objectives to limit damage and loss of operations under expected moderate to major earthquake events. Analysis and design of the steel superstructure gravity and lateral systems was completed in compliance with provisions of the 2007 *California Building Code* (CBC) and ASCE 7-05 requirements including design review panel oversight.

Superstructure Framing

The gravity steel-framed structure consists typically of a 3¼-in. lightweight concrete fill over 3-in. 20-gauge metal deck. Composite steel floor framing at the mechanical level, roof penthouse, Level 1 and below grade levels consists of 4½-in. normal weight concrete fill over 3-in. 18-gauge metal deck. The standard floor plan, with an open, column-free layout and story height of 16 ft, accommodates the courtrooms with clear ceiling heights of 12 ft.

The lateral force resisting superstructure system consists of steel special moment frames (SMF) on essentially all frame grid lines in each direction and at each level, with 184 distributed supplementary viscous damping devices (VDD), made by Taylor Devices, Inc., with extender brace elements. The superstructure frame is supported on an energy-dissipating seismic isolation system above the lowest mat foundation level. The steel SMFs consist typically of reduced-beam section (RBS) W24 beam/girder two-way moment connections to 18-in. to 24-in. square built-up box columns and W24 cruciform column elements in conformance with the prequalification connection



- ▶ The steel-framed superstructure above the seismic isolation plane.
- ▶ Consisting of two building elements—an 11-story courtroom tower and an interconnected, three-story podium—the new building contains 35 courtrooms and consolidates functions that had previously been spread throughout the county across 12 different buildings.



▶ The new San Bernardino Justice Center is one of the tallest seismically base-isolated buildings in the U.S.



Mark Sarkisian is a partner, **Peter Lee** is associate director, **Lindsay Hu** is an associate and **Alvin Tsui** is an associate, all with Skidmore, Owings and Merrill, LLP, in San Francisco.



▲▼ The superstructure frame is supported on an energy-dissipating seismic isolation system above the lowest mat foundation level. This system is made up of 69 triple concave-friction pendulum (TC-FP) bearings.

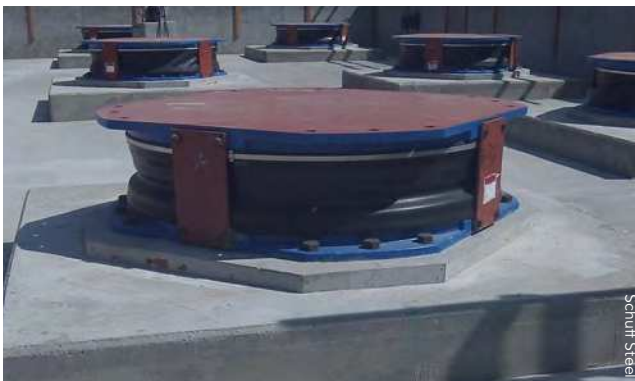

criteria of AISC 341-05 and AISC 358-05. The VDD brace elements have a 440-kip design force with a +/- 5-in. stroke capacity. VDDs control seismic drift demands while the SMFs minimize uplift on the base seismic isolation system.

Seismic Isolation System

The seismic isolation bearing system, manufactured by Earthquake Protection Systems (EPS), consists of 69 triple concave-friction pendulum (TC-FP) bearings located above the base mat foundation. The TC-FP isolation bearing system will accommodate up to 42 in. of lateral movement at the seismic isolation plane and perimeter moat walls. The bearings transfer gravity and lateral forces to the supporting foundation subgrade via reinforced concrete pedestals and mat foundation slab system.

The isolation plane was carefully selected at below the lowest occupied level and at perimeter building perimeter conditions to minimize the number of building utilities and service elements required to be detailed to accommodate movements across the plane. Locating the isolation plane above the mat foundation required approximately 55,000 sq. ft of steel-framed space at the lowest occupied building level.

Analysis modeling of each seismic isolation bearing was developed on the basis of assumed mechanical properties of the TC-FP bearings, verified by both prototype and production bearing testing. Architect and structural engineer SOM collaborated with EPS during the design phases in evaluating five different bearing geometries and properties, each with two or more bear-

Triple Concave Friction Pendulum (TP-FP) Isolator Geometry

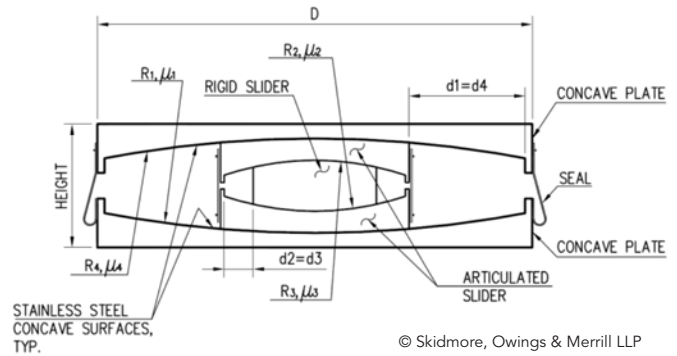

TC-FP Isolator Force-Displacement Properties

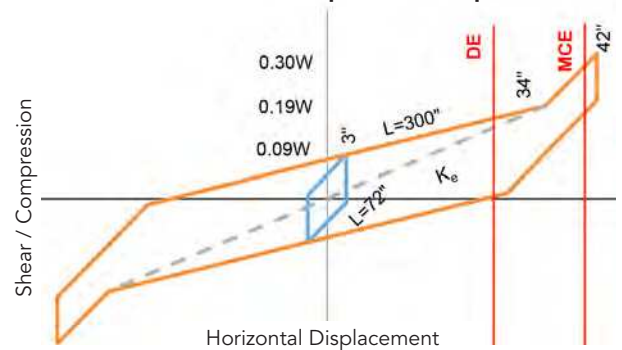

ing types, in determining the most appropriate and optimal isolation system properties for the isolated structure in response to the site-specific ground motion criteria.

The effective radii (L) of the outer and inner concave surfaces are 300 in. and 72 in., respectively, and the friction coefficients of breakaway, target, lower bound (LB) and upper bound (UB) are 5.0%, 9.0%, 7.5% and 10.5%, respectively. The upper and lower sliding surfaces have equal friction coefficients, and UB and LB properties include adjustments for potential aging and contamination effects. Modeling the TC-FP was based on the equivalent bilinear model to represent the breakaway friction coefficients of inner and outer sliding surfaces. The structural analyses included the bounded analysis of the UB and LB friction coefficients to determine maximum force and displacement demands. EPS confirmed analysis parameters based on the results of a prototype bearing testing program conducted during the construction document phase under direction of SOM and the design review panel.

Damping Devices

The VDDs have a nonlinear velocity exponent of 0.5, a damping constant of 150 kip-sec/in., a maximum stroke capacity of ± 5 in. and a maximum design force of 440 kips. The structural analyses included the bounded analysis of $\pm 15\%$, using the upper and lower bound damper properties of a damping constant. The VDD elements were modeled using nonlinear damper elements in ETABS, and the damping devices were

- The lateral force resisting system incorporates 184 distributed supplementary viscous damping devices (VDD) with extender brace elements.

designed to have displacement and design force demands for maximum considered earthquake (MCE) level ground motions. The connections and extenders transferring the damper forces to the structural members were designed to develop maximum forces in the damping devices. Since the damper forces are substantially out-of-phase with elastic forces, the dampers do not significantly increase loading on the structural members while providing significant levels of damping in response to earthquake loads.

Using seismic isolation and VDDs significantly reduces base shears, overturning moments, story drifts and floor accelerations. The seismic isolation system effectively reduces the superstructure floor accelerations by increasing the period and controls base displacements with increased damping and energy dissipation. The supplemental VDDs absorb a significant amount of seismic energy, further reducing the story drift demands in the superstructure. The vertical displacement of the isolation bearings was reduced significantly below the maximum allowable story drift of 0.015. The story drift ratios were estimated from the analysis results from the upper bound and lower bound damper models with upper bound and lower bound seismic isolation system properties.

Based on the series of nonlinear response-history analyses, the maximum average drift ratios are about 1.4% under the design earthquake (DE) and about 1.7% under maximum (MCE) ground motions. The maximum story drift and floor acceleration demands in the seismically isolated building are significantly smaller than that in a fixed-based building due to the decoupling effects of the seismic isolation system. Significant enhanced seismic performance is achieved using both the VDD and isolated systems to reduce peak floor acceleration and drift demands to minimize damage on sensitive nonstructural elements and components.

- A typical damper device connection detail.



© Skidmore, Owings & Merrill LLP

**San Bernardino Justice Center
Maximum Inter-Story Drift**

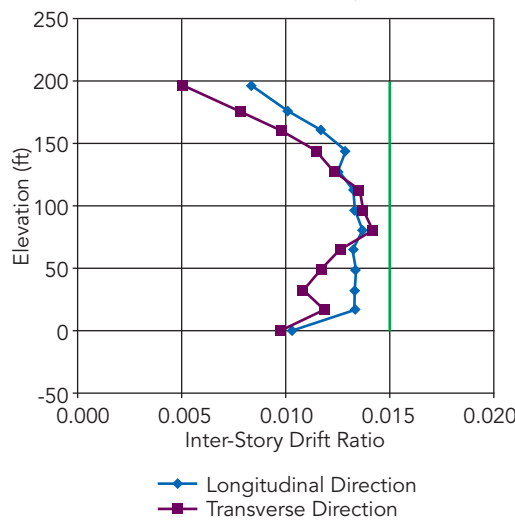

**San Bernardino Justice Center
Maximum Floor Acceleration**

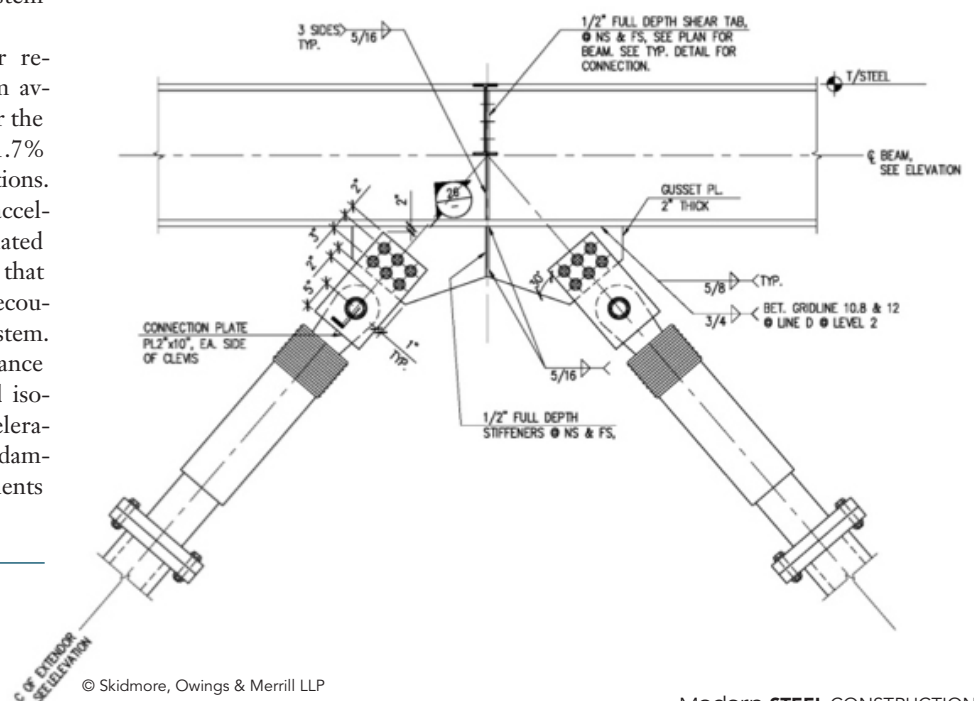
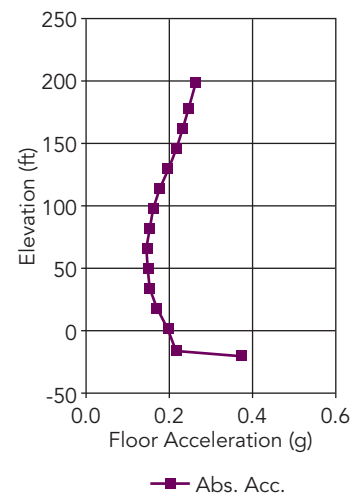

© Skidmore, Owings & Merrill LLP

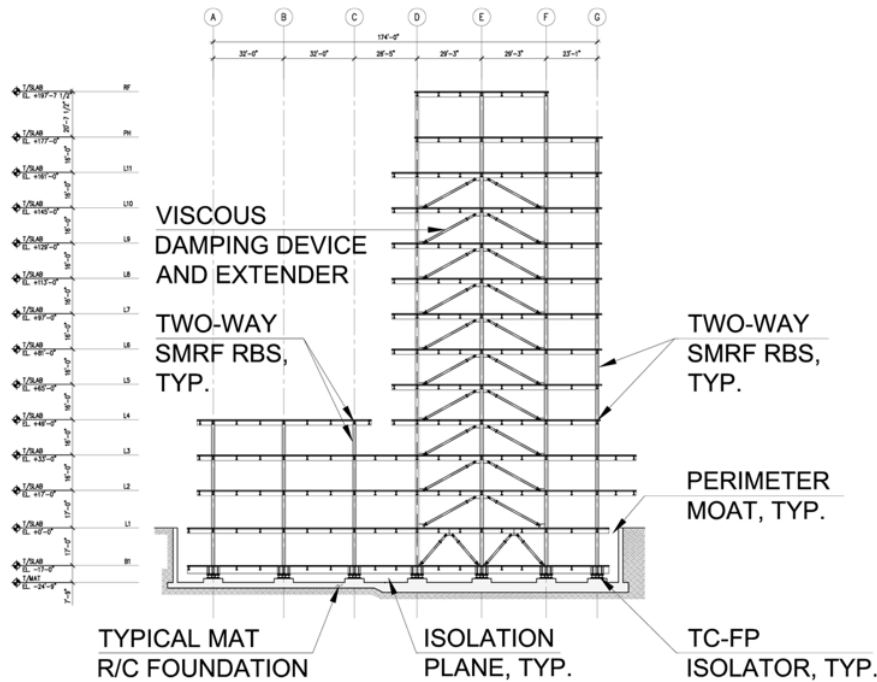

© Skidmore, Owings & Merrill LLP

◀ Typical gravity and lateral steel framed superstructure. Elevation, top; Plan view, bottom.

Center's new construction, which provides for the recording of earthquake motion data within, below and adjacent to the building during earthquake induced events. Basic elements of the instrumentation layout included 36 sensors (32 accelerometers and four relative displacement sensors) within the building as well as three ground station (free field) sensors at the southeast corner of the building site. All accelerometers are interconnected to centrally located computer controlled digital recording equipment for common start, timing and synchronization. In coordination with the general contractor and subcontractors, CSMIP provided support and assisted in the installation of the SBJC's seismic instrumentation system while providing long-term maintenance and ongoing monitoring during future seismic events as part of California's statewide network. Originally targeting LEED Silver certification from the U.S. Green Building Council, the courthouse achieved LEED Gold at no added cost, in part thanks to its comprehensive consideration of earthquake resilience. ■

Seismic Risk and LCA

Consistent with an "enhanced" seismic performance objective for the SBJC, this is the first project for which the JCC embraced life-cycle analysis (LCA) to consider the impact of alternate structural systems on the long-term seismic performance and the relative return on investment in a region of high seismicity. In collaboration with Certus Consulting, Inc., SOM conducted a seismic risk assessment and LCA based on a 25-year return period during design development to inform client deci-

sion making. The evaluation of alternate conventional fixed-based (non-isolated) options showed an 18.5% return on investment for the seismically isolated superstructure that included estimated mean annual losses from damage to structural, nonstructural (drift and acceleration sensitive) and building contents, as well as loss of use and business interruption impacts.

Working with the California Strong Motion Instrumentation Program (CSMIP), SOM developed a strong motion seismic instrumentation system as part of the Justice

Owner

Judicial Council of California, State of California

Construction Manager/General Contractor

Rudolph and Sletten

Architect and Structural Engineer

Skidmore, Owings and Merrill LLP

Steel Team

Fabricator and Erector

Schuff Steel 

Detailer

Steel Systems Engineering, Inc. 