

---

**ENERGY MANAGEMENT UTILIZING  
THE HYDRAULIC SHOCK ABSORBER**

---

**by**

**Douglas P. Taylor, President**

**Taylor Devices, Inc.**

**90 Taylor Drive**

**P.O. Box 748**

**North Tonawanda, NY 14120-0748**

# **ENERGY MANAGEMENT UTILIZING THE HYDRAULIC SHOCK ABSORBER**

Douglas P. Taylor  
Taylor Devices, Inc.  
North Tonawanda, New York

## **INTRODUCTION**

The advent of high speed equipment and machinery has brought with it numerous problems associated with slowing and stopping masses of various forms. The hydraulic shock absorber has proven itself to be one of the most satisfactory means of solving these problems, yet the shock absorber still remains as one of the least understood fluid power components.

Presented are design constraints, design parameters, and state-of-the-art technology used to incorporate a self-contained shock absorber into a system for the purpose of dissipating kinetic energy.

Information is presented in both qualitative and functional equation format to enable the reader to grasp the subjective aspects of shock absorber usage which go beyond normal mathematical constraints.

## **THE SHOCK ABSORBER**

The hydraulic shock absorber is one of the least understood fluid power components, both in functional and design considerations. The reasons for this phenomena are several:

1. The modern hydraulic industrial shock absorber fulfills requirements which did not exist 30 years ago.
2. A shock absorber is usually used in a mechanically, electrically, or hydraulically actuated system only when all other means have failed to eliminate an energy overage
3. In most systems, the duty cycle of the shock absorber consists of intermittent operation for a duration of only a fraction of a second.

To understand the shock absorber, one must first define it, and the most often used definition would be as follows:

“A shock absorber is a device which produces a dissipative (non-recoverable) force over a given displacement to absorb energy and remove it from a system.”

Strangely enough, the above definition is not entirely correct, since modern day applications show that a component which could be defined as a shock absorber in one particular system might not be a shock absorber in another. For example, a common item in any auto parts store is the “shock absorber” used in an automotive suspension system. The common “auto shock” is indeed a shock absorber if one removes it from the car. If one pushes on the device, or hits it with a weight moving at a speed, it will meet the above definition of a shock absorber, and produce a force over its displacement. The output force is dissipative in that the piston rod does not restore any of the applied force back to whatever caused it to move. The output force of any shock absorber is usually produced by forcing fluid through restrictive orifices. As the fluid is forced through the orifice, thermal energy is given off and the heat, once mechanical energy, is removed from the system due to the thermal processes of conduction, convection, and radiation. The amount of energy absorbed by the shock absorber is the integral of its output force over displacement, or:

$$E = \int F dx$$

Where E = energy

F = shock absorber output force

X = shock absorber piston displacement (stroke)

A shock absorber of the auto suspension type is fine for absorbing energy if you only hit it once. This is because the device, being a dissipative component, does not reset itself. To be reusable, one usually adds a reset means of some form. Thus, most shock absorbers are combined with a reset means, usually a mechanical, air, or gas spring, to be of any repeatable use. The problem which arises in an automotive suspension is the magnitude of the spring used. In the suspension, the shock absorber does not absorb any large amount of energy, relative to the springs in the suspension. In fact, a car without shock absorbers can hit bumps and potholes without any real difficulty except for bouncing along in a hard to control fashion after impact. This is because the shock absorber is actually being used as a damper in the suspension system, to control the motion of the springs. Any large bump inputs have the bump energy stored by the springs, so that after the vehicle has traversed the bump the spring will reset the suspension to its original static ride position, without causing undue motion of the vehicle body.

In conclusion, the common auto shock meets the most common definition proposed earlier, yet it is not the component known as a shock absorber in modern, industrial usage. One finds that a more descriptive definition is:

“A shock absorber is a device which:

1. Produces a dissipative output force over a given displacement to absorb energy and remove it from a system.
2. Includes a reset or restoring means to reposition it after it has absorbed energy, the reset means being such that its resetting energy is much smaller than the absorption capacity of the device.”

By using the above definition, one can discuss what is known in the industry as a shock absorber without becoming bogged down in considerations of damped spring systems, vibratory isolation systems, etc., all of which are completely different components, even though they all include the absorbing of energy as part of their output. The definition which applies to the suspension shock would be that of a damper:

“A damper is a device which produces a dissipative output force over a displacement, in a spring-mass system.”

To study the shock absorber, one must study metering and reset systems separately in order to more fully understand design constraints for each of these two major parts of the shock. Since seals, finishes, materials, etc. are similar in operation to most standard fluid power components, no great discussion concerning these parts will be given.

### THE SQUARE-WAVE EFFICIENCY OF A SHOCK ABSORBER

A shock absorber uses the metering of fluid to absorb energy. Since the job of the device is to remove energy from a system with the fewest possible repercussions to the rest of the environment, it can be easily understood that the idealized metering system would enable the input energy to be absorbed within an envelope of minimum reaction force and minimum force.

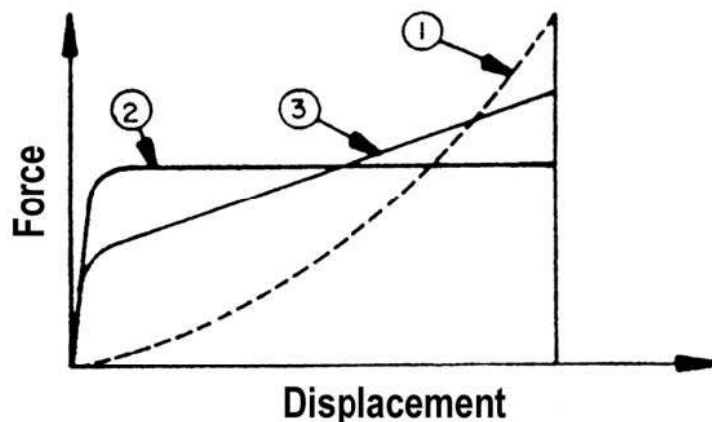

FIGURE 1

Figure 1 shows a force-displacement diagram with 3 different types of force-displacement curves superimposed over one another. The energy absorbed by each of the output curves is the integral of the output force over increments of displacement, which is represented by the area under the curve. In Figure 1, the areas under each of the 3 hypothetical output curves are equal, yet output curve 2 yields the energy capacity with a much lower force than curves 1 or 3. Obviously then, the best possible metering system would be a perfectly square wave, since any other wave form would require more output force to absorb the input. More output force means that the system

being decelerated via energy absorption requires a more rugged design to withstand the higher force and higher deceleration rate imposed by a less than square wave. All shock absorber manufacturers strive for the squarest possible wave form, and often go to great lengths to attempt to show that their design yields the squarest output curve. Manufacturer's phrases used to describe a square wave shock absorber include:

- Constant force output
- High efficiency
- Linear output
- Linear deceleration
- Lack of peak force
- Flat-topped output
- Linear output dashpot

All shock absorbers claiming one or more of the above features are really all designed to yield the same basic output. Some manufacturers have metering which is not capable of achieving anything which approximates a square wave, and they often claim that square wave output is not the best. Their claims are, of course, in violation of the Laws of Newton, which govern all problems of deceleration. In accordance with these laws, the higher the output force, the higher the resulting deceleration rate will be.

A quantity known as the efficiency or wave form coefficient is used to describe how square an output curve is. The efficiency is the ratio of square wave output force to actual output force for a given application.

$$\text{Efficiency} = \frac{\text{Square wave output force}}{\text{Actual output force} \times 100\%}$$

Obviously a square wave output is 100% efficient.

The lack of understanding of efficiency in a shock is wide-spread, often leading to anxious purchasers demanding efficiencies of over 100%, which is theoretically impossible.

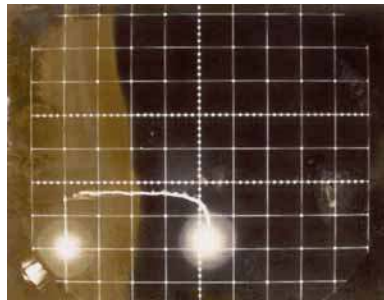

**FIGURE 2**

Figure 2 is an oscilloscope photo of a highly efficient shock absorber output. This output curve is 93% efficient.

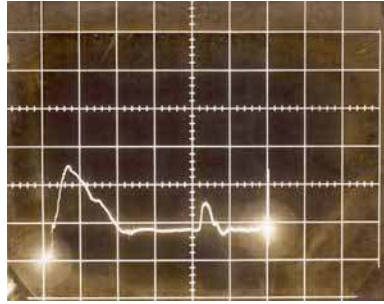

**FIGURE 3**

Figure 3 is an output photo of an inefficient shock absorber (also referred to in the industry as a “linear decelerator”). This product’s efficiency is only 40%. The input energy in Figure 2 and Figure 3 are identical, but the inefficient “linear decelerator” requires 50% more force and 42% more stroke to absorb the input.

Many shock absorber manufacturers do not like to disclose actual operating efficiency, since a low efficiency implies an antiquated or bad design, or a mis-application for that particular design. If in doubt, ask the manufacturer for an actual output curve photo of the shock in question, not a tracing, or “certified calculations.” In lieu of this, obtain catalog data on the maximum rated capacity of the shock, and back-up structure design loads for the size of shock in question.

If one takes the energy capacity, and divides by the stroke of the shock, the result is the square wave output force. Dividing this force by the back-up structure design force will yield the efficiency.

For example:

1. The maximum capacity of a shock is 10,000 in-lb., with a shock absorber stroke of 4 in.  
Back-up structure design force is 4,000 lb.
2. Calculate the square wave force by dividing energy capacity by stroke:

$$\text{Square wave force} = \frac{10,000 \text{ in} - \text{lb.}}{4 \text{ in. stroke}} = 2,500 \text{ lb.}$$

3. Calculate efficiency by dividing square wave force by back-up structure design force:

$$\text{Efficiency} = \frac{2,500 \text{ lb.}}{4,000 \text{ lb.}} \times 100\% = 62\%$$

The efficiency of a shock absorber is determined by the sophistication of the metering system used. Efficiencies of 50-80% are common in low line industrial shock absorbers, with top line or

aerospace type designs capable of 80-90%. If substantial testing and “de-bugging” of the metering system is done, efficiencies of 95% can be obtained, although usually at a very high cost.

The efficiency of a shock absorber is its most important design criteria. It is the efficiency which determines how much stroke is required to decelerate a load. Efficiency becomes most important in high velocity impacts (5 ft/sec. and greater) where long strokes are often required. For example:

1. An energy input of 10,000 in-lb. is to be absorbed by a shock absorber. The object to be stopped can withstand a decelerating force of 4,000 lb. without structural damage.
2. Two shock absorber designs are to be considered:
  - a. A shock with a capacity of 10,000 in-lb., with a 3 in. stroke, with 90% efficiency
  - b. A shock with a capacity of 10,000 in-lb. with a 6 in. stroke with 40% efficiency
3. For either shock absorber in 2a, the output force can be calculated using the formula:

$$\text{Shock force} = \frac{\text{Energy}}{\text{Stroke} \times \text{efficiency}}$$

4. For the 3 in. stroke shock in 2a, the formula yields:

$$\text{Shock force} = \frac{10,000}{3 \text{ in.} \times .9} = 3,700 \text{ lb.}$$

For the 6 in. stroke shock in 2b, the formula yields:

$$\text{Shock force} = \frac{10,000}{6 \text{ in.} \times .40} = 4,166 \text{ lb.}$$

As the results show, one cannot always assume that the shock absorber with the longest stroke will give the “softest stop.” In this case, the inefficient shock had twice the stroke of the more efficient design, yet yields a much higher, and in this case unacceptable output force.

Those skilled in the art of fluid mechanics often ask “Why can’t all metering systems yield high efficiency if they are correctly designed according to established fluid flow equations?” The answer is simple. To properly apply fluid flow equations (Navier-Stokes) to a shock absorber and obtain an accurate answer is an almost insurmountable task, due to the abundance of variables involved. With a shock absorber it is not possible to “knock-off” the so-called “higher order terms” in the Navier-Stokes equations, simply because the higher order terms greatly affect the output of the shock. When impacted, most shock absorbers available today operate at dynamic pressures of 3,000-15,000 psi. At a pressure level of 10,000 psi, fluid is moving through the orifice passages in the shock at an average speed on the order of 1,200 ft/sec. To

mathematically predict the performance of a fluid at this velocity is extremely difficult. This is why actual impact testing is such an important facet in the manufacturing of a shock absorber, and why shock absorbers available on the market today vary so widely in efficiency. In fact, efficiency for a given shock absorber design will vary according to the impact speed it is set up for. A design which produces an efficiency of 80% at an impact speed of 4 ft/sec. may only be 65% efficient when re-orificed or adjusted for the same output force in an impact speed of 10 ft/sec. In ballistics applications at velocities of 100 ft/sec., the same shock might have its efficiency drop to 20% because of internal flow restrictions that caused no restriction at lower velocities. The key in designing efficiency into a shock absorber lies in the design of the metering system of the shock.

## **SHOCK ABSORBER METERING, AND METERING SYSTEMS**

It is the job of the metering system to enable the shock absorber to absorb energy in an efficient manner. In most applications, the design goal is to enable the shock absorber to decelerate a moving weight, often powered by some means, to a terminal speed of zero or nearly zero. To obtain the idealized constant force output, the metering system must be capable of maintaining a constant pressure, even though the impacting weight is having its velocity slowed to zero by the shock. This means that the effective orifice area of the shock must be reduced as its stroking velocity is reduced, to maintain the constant pressure.

The majority of products available today from the 10 largest manufacturers of industrial shock absorbers utilize only 4 types of metering:

1. Fixed orifice metering
2. The metering tube
3. The metering pin
4. Fluidic control metering

These four types of metering will be discussed and compared as to performance, reliability, and efficiency in both adjustable and non-adjustable configurations.

To understand the behavior of various types of metering systems, one must first understand the basic shock absorber output curve. Several different force-displacement output curves have been shown earlier, but to discuss metering systems a knowledge of the trade terminology must be obtained. Figure 4 shows a shock output curve that exhibits practically every abnormality known in the shock absorber business. Various points and areas of the curve have been labeled.



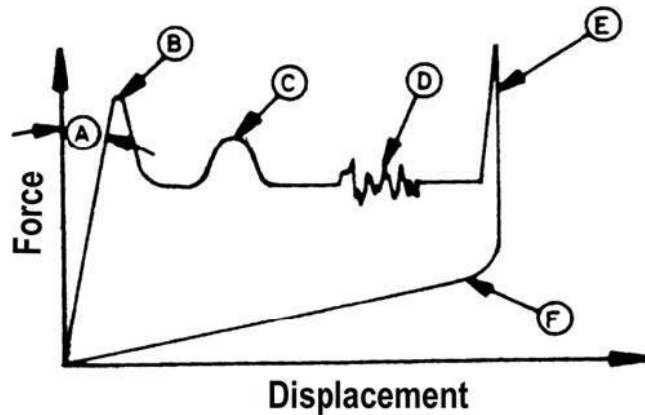

**FIGURE 4**

The curve shown in Figure 4 begins at the intersection of the force and displacement axis. As the shock absorber builds up pressure by metering fluid the angle labeled “A” in the Figure will result. This angle, known as the “rise time angle” or “nose angle,” occurs because of a slight compressibility of the fluid column in front of the shock absorber piston, and because most metering systems cannot respond instantaneously to an impact of the shock. The “rise time angle” has little effect on shock absorber performance other than the loss in shock absorber efficiency that it causes.

Point “B” in Figure 4 is defined as a momentum (or contact) spike. After the spike occurs, the output force drops substantially. Momentum spikes can be caused by several reasons, including:

1. An inefficient or improperly designed metering system.
2. A binding of internal parts due to severe side loading or mis-alignment of the shock.
3. Impacting the shock with a weight of the same magnitude as the weight of the moving parts of the shock absorber.

Item 3 above is the most technically interesting of the three, since it occurs because of the user or manufacturer neglecting Newton’s Law of Momentum Conservation. This law basically states that the momentum (the product of impact mass times velocity) of the impact weight just prior to impact must be equal to the momentum of the weight and shock absorber piston just after impact. If we assume equal mass for the impact weight and the shock absorber piston, the following results:

Momentum before impact = momentum after impact

$$M_1 V_1 = (M_1 + M_2) V_2$$

but, since  $M_1 = M_2$ ,

$$V_2 = \frac{1}{2} V_1$$

Considering the energy before and after impact yields the following:

$$KE_1 = \frac{1}{2} M_1 V_1^2$$

$$KE_2 = \frac{1}{2} (M_1 + M_2) V_2^2$$

But, since  $M_1 = M_2$

$$\text{and } V_2 = \frac{1}{2} V_1$$

Substitution yields:

$$KE_2 = \frac{1}{2} (2M_1) \left(\frac{1}{2} V_1\right)^2$$

$$KE_2 = \frac{1}{4} M_1 V_1^2$$

This means that due to conservation of momentum,  $\frac{1}{2}$  of the initial impact energy will be dissipated before the shock absorber even begins to stroke. This energy must be dissipated as a localized mechanical deflection of the shock absorber piston and/or impact weight. Because the weight and the shock piston normally are several orders of magnitude more rigid than the force output of the shock, the momentum transferral energy will show up in the shock absorber output curve as a force-spike. To eliminate momentum or contact spikes, the shock absorber piston mass must be substantially reduced so that as little impact energy as possible is lost during the momentum transfer.

Point "C" in Figure 4 is known as a metering spike. It occurs because of a restriction existing in the metering system due to improper design.

Point "D" in Figure 4 is merely instrument noise. Instrument noise is usually caused by improper grounding of the instrumentation system by interference from an A-C power source close to the instrumentation system, or by faulty instrumentation. Since this apparent force ripple is caused by the recording device and not the shock, it can be neglected.

Point "E" in Figure 4 is a bottoming spike. The bottoming spike occurs because the shock absorber has not absorbed all of the impact energy within its stroke, and after bottoming will act just like a rigid bar of steel. Bottoming spikes will fail the shock absorber, the impact weight, or the structure the shock is mounted on in very short order. For example, a man hitting a bar of steel with a small 1 lb. hammer can generate a force spike of over 50,000 lb. with great ease.

Since shock absorbers are usually used to stop much larger amounts of energy, the bottoming spike will very quickly go up to several million lbs., usually more than enough to start crushing or deforming metal somewhere in the shock absorber. Bottoming spikes occur because the input energy to the shock has been improperly calculated. This might well be a fatal miscalculation.

Area “F” in Figure 4 is known as a rebound. This means that the shock absorber has not absorbed energy, but merely has stored it and will re-impart this energy to the impacting weight as a “bounceback.” A rebound occurs because the shock absorber has:

1. Too stiff a reset mechanism
2. One or more blocked orifice passages
3. An improperly designed metering system

Usually all of the problems shown in Figure 4 can be avoided by proper selection of a shock absorber from a reputable manufacturer, or by getting the manufacturer’s recommendations for the application.

#### A. THE FIXED ORIFICE SHOCK ABSORBER

The fixed orifice metering system is the oldest shock absorber metering system. A typical fixed orifice shock absorber is shown in Figure 5.

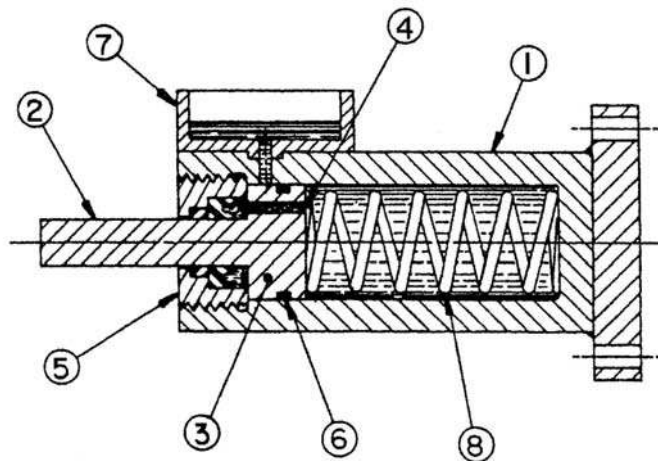

**FIGURE 5**

A description of the internal parts:

1. Cylinder
2. Piston rod
3. Piston head
4. Orifice hole
5. End cap and seal assembly (low pressure)
6. Piston head seal (high pressure)
7. Piston rod displacement accumulator
8. Return spring

In operation, fluid is forced through the fixed orifice passage producing a pressure acting over the diameter of the piston head, which produces a resisting force on the piston rod. To compensate for the displacement of the piston rod entering the cylinder, a piston rod displacement accumulator is used.

The biggest problem with the fixed orifice shock absorber is its lack of efficiency. Maximum output efficiency is usually only around 30% with this type of design. This is because the fixed orifice varies the shock pressure with the square of the fluid velocity through the orifice. This means that if we try to stop a moving weight with this type of shock, a very high initial force will be produced, which decays parabolically as the shock absorbs energy and slows down the impact weight.

Figure 6 shows the output of the fixed orifice shock absorber at 2 different impact velocities,  $V$  and  $2V$ .

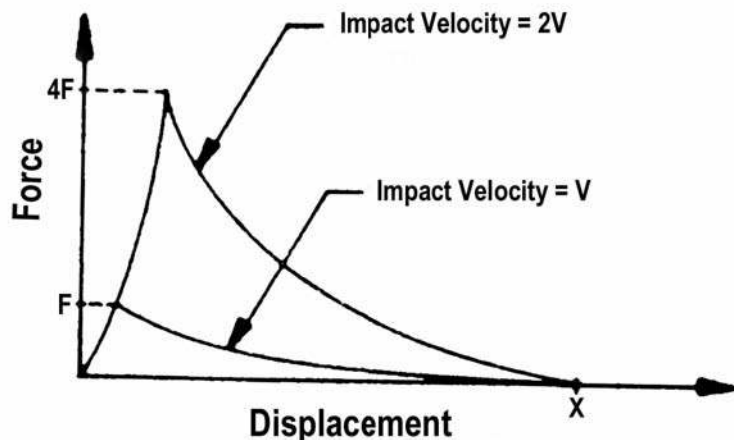

FIGURE 6

Note that the 2 curves are of the same basic shape, the output force going up by a factor of 4 as the velocity doubles. This reaction is due to the output force of this device varying with the square of the velocity. Note that since the impact energy also changes with the square of the impact velocity, the stroke of the shock will not change as one varies impact velocity. Unfortunately this also means that the application of a drive force in addition to a kinetic energy input will cause the shock to violently bottom out with an output spike. In summary:

The Fixed Orifice Shock Absorber –

*Advantages*

1. Low cost
2. Simple design

*Disadvantages*

1. Low efficiency
2. Inability to resist drive force inputs
3. At least one high pressure seal is required

**B. THE METERING TUBE SHOCK ABSORBER**

The metering tube shock absorber is actually a series of fixed orifice shock absorbers with the orifice area being reduced as the shock absorber strokes. A typical metering tube shock absorber is shown in Figure 7.

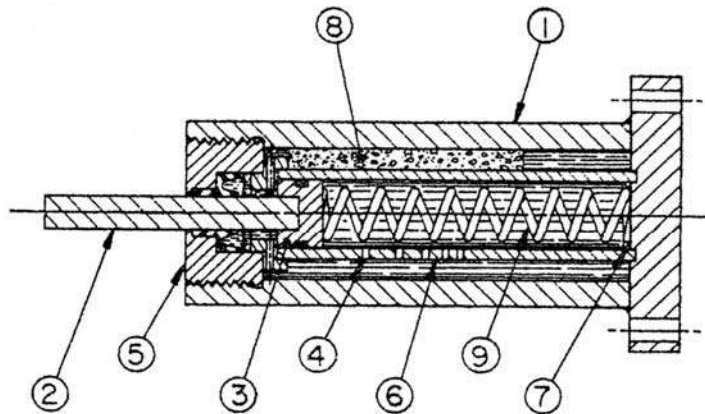

**FIGURE 7**

A description of the internal parts:

1. Cylinder
2. Piston rod
3. Piston head and high pressure seal
4. Orifice hole (one of 5 shown)
5. Metering tube
6. Metering tube high pressure seal
7. Piston rod displacement accumulator
8. Return spring

At impact, fluid will be forced through all of the orifice passages, yielding a fixed orifice area until the piston head passes the first orifice hole, yielding a second fixed orifice area until the head passes the second orifice hole. This process continues in like manner until the shock absorber stops the impacting weight. Piston rod displacement is compensated for by an accumulator, often of cellular rubber construction.

The metering tube shock absorber can be set to yield high efficiency, if a large number of orifice hole positions are used. The more orifice positions the shock has, the more uniform its output curve. The number of positions actually used relative to stroke in shock absorbers available on the market today varies drastically. In 2 in. stroke units for example, some manufacturers use as little as two orifice positions, and some use as many as six. To obtain maximum efficiency, parabolic position placement is often used, with the most positions toward the end of the stroke. Note that to seal the metering tube to the cylinder bottom, a second high pressure seal is required, unlike the fixed orifice type of shock which uses only a single high pressure seal.

If properly designed, the output of the metering tube shock absorber will be basically square wave in appearance, with small metering spikes occurring each time the piston head passes a metering hole position.

Metering tube shock absorbers on the market today usually have efficiency values ranging between 40% and 80%.

Because the metering tube is basically a series of fixed orifices, output force for a given impact velocity will vary with the square of the impact velocity.

Figure 8 shows the output of a metering tube shock absorber at 2 different velocities,  $V$  and  $2V$ .

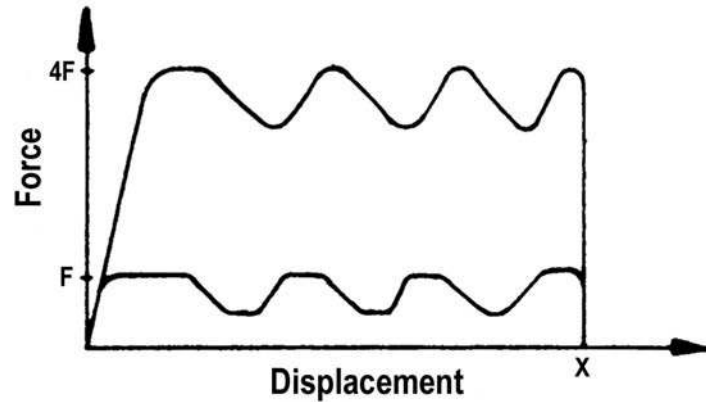

**FIGURE 8**

Note that the output curves are much more efficient than a fixed orifice shock, and also that the magnitude of the output curve varies with the square of the impact velocity. Like the fixed orifice shock absorber, the stroke will always remain constant over conditions of changing impact velocity. Also like the fixed orifice shock, the application of a drive force in addition to a kinetic energy input will cause the shock absorber to bottom out with an output spike. However, with a metering tube, one can compensate for drive energy inputs by drastically reducing the orifice area of the last few orifice positions. This alteration, frequently known as mill-type, crane type, or end cushion metering, will allow the shock absorber to better withstand a drive input, but a penalty is paid in that curve efficiency drops to between 30% and 60%. In summary:

The Metering Tube Shock Absorber –

*Advantages*

1. High efficiency is properly designed
2. Moderate cost

*Disadvantages*

1. Inability to resist drive forces unless efficiency is sacrificed
2. At least two high pressure seals are required

### **C. THE METERING PIN SHOCK ABSORBER**

Metering pin shock absorbers carry the concept of the metering tube one step further in that the effective orifice area is continuously varied as the shock absorber strokes. In comparison to a fixed orifice shock, the metering pin simulates an infinite number of fixed orifices. A typical metering pin shock absorber is shown in Figure 9.

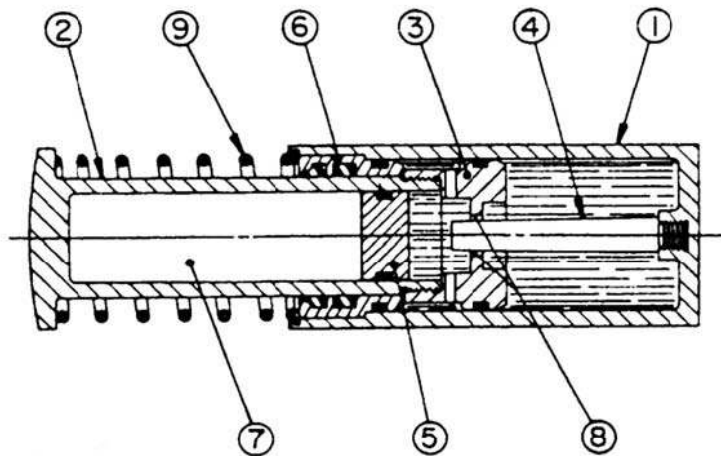

**FIGURE 9**

A description of the internal parts:

1. Cylinder
2. Tubular piston rod
3. Piston head and high pressure seal
4. Metering pin
5. Separator piston and low pressure seal
6. End cap and seal assembly (low pressure)
7. Piston tube displacement accumulator chamber
8. Metering orifice
9. Return spring

At impact fluid is forced through the metering orifice created by the clearance between the piston inside diameter and the metering pin outside diameter. As the shock absorber strokes, the orifice area is progressively reduced as the metering pin diameter increases, due to its tapered profile. Piston rod displacement is compensated for by the floating separator piston which compresses air in the accumulator chamber as it is moved due to piston displacement.

The metering pin shock absorber theoretically can yield much higher efficiency than a metering tube type design, since the orifice will be changed in a continuous fashion by the tapered pin. Efficiency is determined by the linear “profile” of the metering pin over the stroke of the shock absorber. As can be easily understood, the proper profile for a metering pin is a parabolic profile. Unfortunately this profile is exceedingly difficult to manufacture, especially if many different sizes of orifices are to be made for different impact velocities, different applications, etc. Indeed, the metering tube design is far easier to work with and much less expensive to produce than the metering pin design. Because of this, all metering pin shock absorbers available today use some sort of a “compromise” profile that can be mass-produced inexpensively. Most



metering pin shock absorbers available today use a straight (or linear) pin taper rather than the highly efficient parabolic taper, and settle for efficiencies of 40% to 80%, the same as most metering tube designs.

Note that the use of a hollow piston tube usually yields a larger and more rugged design than other types of shocks, and this design is better able to resist offset (angular) impact loads. However, a penalty is paid in that much larger seals are required for any given size shock, yielding a higher leakage rate and shorter life.

A common problem with metering pin designs is flexure of the pin during impact conditions. Because the pin itself is long and slender and fastened to the cylinder bottom only, shock pressure will force the pin over to one side of the orifice. When this occurs, efficiency will drop to only 20%-30%, and energy capacity will be drastically reduced. If the pin is made rugged enough, and centered perfectly, this problem will not occur. However, production tolerances often make this impossible.

A second, more serious problem occurring in metering pin designs is a dieseling condition occurring in the piston displacement accumulator chamber. This condition occurs when the shock is overfilled with oil and the adiabatic compression of air in the accumulator chamber increases the air temperature to a high level. If the temperature is high enough, any hydraulic oil leakage in the accumulator chamber will ignite, and the shock absorber piston tube will often explode. The better design metering pin shocks available utilize a second coil spring in the accumulator to load the floating separator, and vent the accumulator chamber to the atmosphere, so that air compression cannot occur.

The overall performance of metering pin shock absorbers is identical to that of metering tube type designs, as shown previously in Figure 8. Output force changes with the square of the impact velocity, and stroke remains relatively constant, Figures 10 A-D show actual oscilloscope output curves of a typical metering pin (or metering tube) type shock absorber at velocities of 1, 2, 3, and 4 mph, when impacted with a fixed weight.

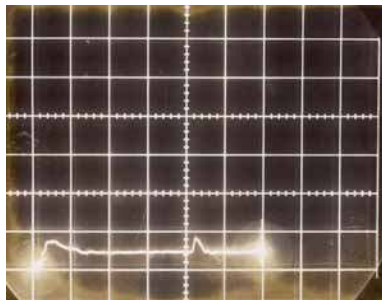

**FIGURE 10-A**

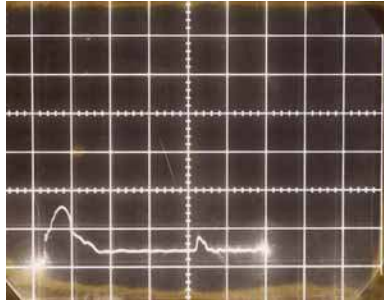

**FIGURE 10-B**

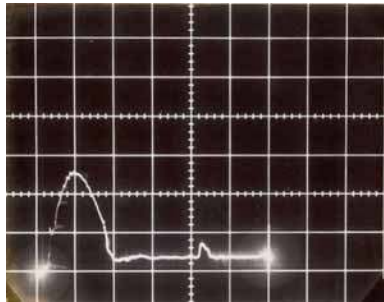

**FIGURE 10-C**

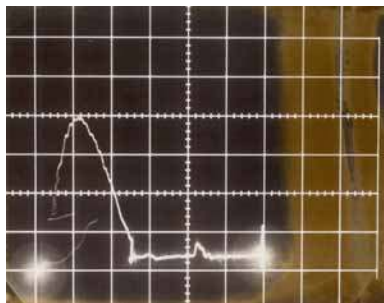

**FIGURE 10-D**

This type of shock also has the same inability to resist drive forces that afflicts the metering tube shock absorber when impacted with a drive input in addition to a kinetic energy input. Drive forces can only be counterbalanced by drastically increasing metering pin diameter toward the latter part of stroke, reducing the effective orifice area to near zero. A penalty is paid as in metering tube designs, in that curve efficiency drops to between 30% and 60%.

In summary:

The Metering Pin Shock Absorber –

*Advantages*

1. High efficiency if properly designed and constructed
2. Large tubular piston rod can resist sideload better than other types of exposed piston rod designs

*Disadvantages*

1. High cost to properly manufacture
2. Inability to resist drive forces unless efficiency is sacrificed
3. At least one high pressure seal is required

**D. THE FLUIDIC CONTROL-METERING SYSTEM\***

The Fluidic Control Metering System is the newest form of shock absorber orificing to be offered. Fluidic Control metering uses specially shaped orifice passages to yield by hydraulic flow the effect of a mechanically varied orifice. A typical fluidic control shock absorber is shown in Figure 11.

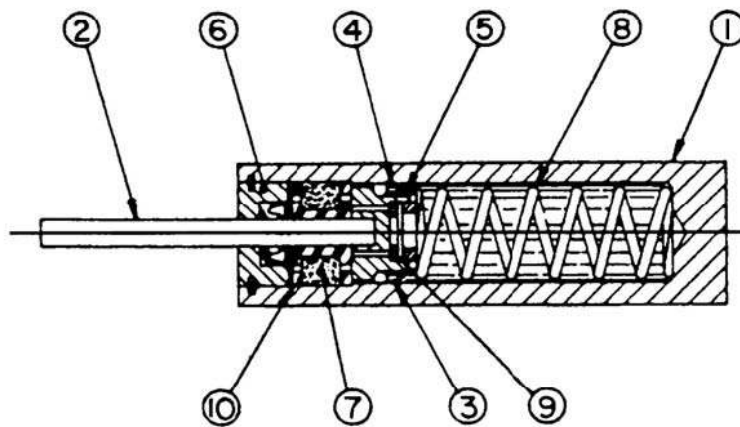

**FIGURE 11**

A description of the internal parts:

1. Cylinder
2. Piston rod
3. Piston head
4. Main orifice
5. Feeder orifices
6. End cap and seal assembly (low pressure)
7. Piston rod displacement accumulator
8. Return spring
9. Reset valve
10. Guide spool

\* Patents issued, pending, applied for - Tayco Developments, North Tonawanda, New York

The operation of this type of shock absorber is not self-explanatory, as are most conventional metering systems. To operate with high efficiency, a compressible working fluid must be used, such as the family of silicone base oils. The molecular structure of the silicone oils allows them to be compressed up to 10% (by volume) when used in the high pressure dynamic environment of a shock absorber at impact. Oils of this type are rarely used in the rest of the field of hydraulic technology because of their compressibility. For example, if one were to use a silicone oil to replace normal hydraulic fluid (which is relatively incompressible) in a typical hydraulic system, the compressibility of the silicone would cause losses in pumping efficiency, and a response lag from every component downstream of the pumping source. If used in a conventional shock absorber of the types previously discussed, the silicone fluid will not affect the basic output curve, but the compressibility will decrease the rise time of the shock, reducing efficiency slightly. A disadvantage of using silicone oil in a hydraulic system is that most conventional commercially available seals are not compatible with this fluid. Special seal designs and materials are usually required. The Fluidic Control Metering System must use a compressible fluid to operate or its efficiency will be about the same as a fixed orifice metering system.

Figure 12 shows a detail of the piston head in a Fluidic Control shock absorber.

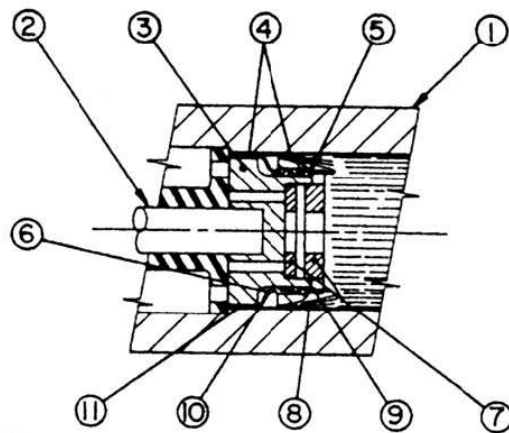

**FIGURE 12**

A description of the details of Figure 12:

1. The shock absorber cylinder (partial view)
2. The shock absorber piston rod (partial view)
3. The piston head
4. Primary orifice passage
5. Feeder orifice
6. Fluid collector groove
7. Reset check valve assembly
8. Primary fluid flow
9. Feeder orifice flow
10. Intersecting flow point
11. Combined flow

When impacted, a shock absorber using the orifice system shown in Figure 12 will attempt to behave like a fixed orifice design, flowing all fluid across the primary orifice passage. Within a few microseconds after impact, the pressure differential across the primary orifice passage has a gradient such that the pressure in front of the piston is higher than the pressure existing at the intersecting flow point. This means that the flow through the feeder orifices will be entrained into the primary fluid flow, yielding a combined flow shown at point 11 in the Figure. Because the working fluid is compressible, these flows can indeed be combined, much as would occur if a gas was being orificed. As the shock absorber absorbs the energy input, and the piston rod velocity decreases, the primary fluid flow shown in the Figure will have its velocity decreased also and the entrainment effect will progressively decrease. The overall affect is such that the orifices will pass a much greater amount of fluid at impact than they will at the end of stroking. This is very similar in response to the metering pin and metering tube types of shock absorbers which mechanically generate maximum orifice area at impact, and minimum flow area at the end of their stroke. The major difference is that the Fluidic Control Metering System regulates its output with respect to the velocity of the fluid flow within it, whereas metering tube and metering pin type designs regulate their output with respect to piston rod position. Because of the very restrictive fluid passages used in this metering system, a return check valve must be used, or the reset spring will have great difficulty resetting the piston.

The Fluidic Control Metering System consistently yields the highest efficiency of any known metering system. Efficiency will normally range between 75% and 95%. The design is relatively insensitive to production tolerances, provided that the cylinder bore and piston head diameter tolerance is held to a minimum. The placement of all the fluid passages, and their relative size, must be laboriously determined by actual testing because of the extreme complexity of the flow equations involved. Once all these parameters have been established for a given size of shock absorber, performance is exceedingly easy to repeat. Figure 13 A-D shows actual oscilloscope photos of a Fluidic Control shock absorber (also referred to as a “Fluidicshok”) being impacted at speeds of 2, 3, 4, and 5 mph by a fixed weight.

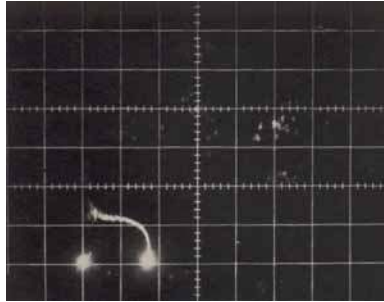

**FIGURE 13-A**

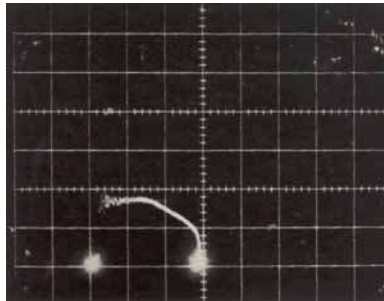

**FIGURE 13-B**

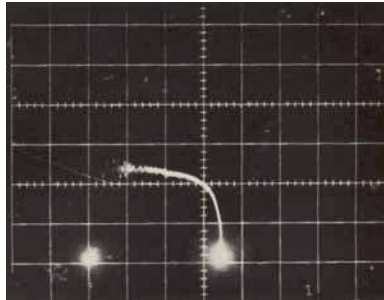

**FIGURE 13-C**

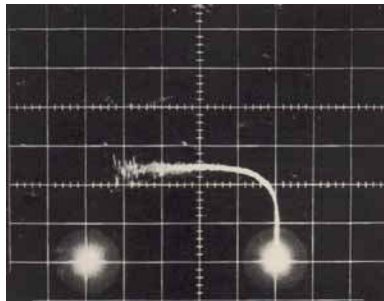

**FIGURE 13-D**

Note the high efficiency of the output curves at all velocities. Note also that unlike all other metering systems discussed here, the Fluidic Control Metering System does not change its output force with the square of the impact speed, but rather increases both output force and stroke in a linear fashion as the velocity increases. This means that for most industrial applications where drive forces are present in addition to a kinetic energy input, the Fluidic Control Metering System will fully stroke without a violent bottoming spike, unlike other types of metering systems. In summary:

The Fluidic Control Shock Absorber (Fluidicshok) –

#### *Advantages*

1. Moderate cost
2. Very high efficiency
3. Uses only a single low pressure seal
4. Can withstand drive force inputs without spiking

#### *Disadvantages*

1. Requires close production tolerances
2. Requires special seal materials to be compatible with the silicone oil required with this design

### **E. THE ADJUSTABLE SHOCK ABSORBER**

Starting about 1964, a different type of shock absorber began to appear in industrial usage. This type of device was the adjustable shock absorber, which could be adjusted in the field for energy capacity. This eliminated the requirements for re-orificing a shock every time a given size was to be used at a different velocity. The adjustable shock absorber also allowed distributor stocking, something that could not be done with custom orificed shocks. Early adjustable shocks were quite crude, using a needle valve controlled fixed orifice shunt across a metering pin or metering tube design. If the needle valve was closed, the shock absorber would behave like any metering pin or metering tube type of shock. As the valve was opened, the shock would begin to perform like a fixed orifice design, with inherent low efficiency. The fixed orifice shunt adjustable shock absorber is shown in Figure 14, applied to a metering pin design.

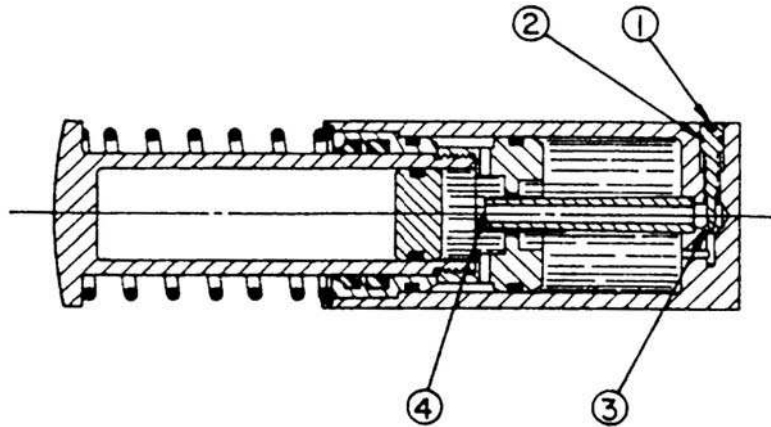

**FIGURE 14**

A description of the parts shown:

1. Needle valve adjustment
2. Valve packing
3. Shunt orifice adjusted by needle valve
4. Shunt discharge to low pressure side of piston head

The efficiency of the fixed orifice shunt style adjustable shock absorber can range from a low of about 30% with the adjustment wide open to a high of 60-80% when the adjustment is fully closed.

Later types of adjustable shocks are usually based upon metering tube type designs. Two metering tubes are used, one inside the other, with a very tight fit between the tubes. The orifice holes are drilled through both tubes so that when one rotates the tube with respect to the other, the orifice will be opened or closed accordingly. Sometimes a tapered slot, or a similar variation, is used in one of the tubes to get a finer adjustment range. Unlike the shunt type adjustment, this sort of design varies the entire orifice in a graduated way, thereby maintaining curve efficiency. As long as no leakage occurs between the tubes, this type of construction will work quite well. Figure 15 depicts this type of shock absorber.



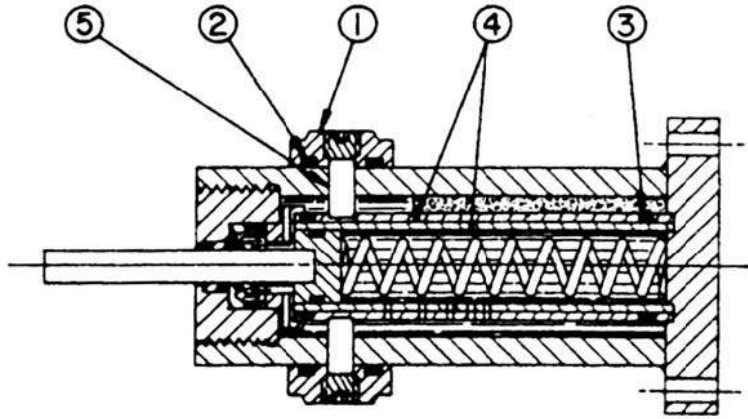

**FIGURE 15**

A description of the parts shown:

1. Adjusting ring (radially rotated about cylinder to adjust)
2. Adjusting ring seals
3. Metering tube seals
4. Metering tubes with orifices drilled through both tubes
5. Adjusting ring drive pin

As can be easily understood, the adjustments on metering tube and metering pin type shocks must be exceedingly large, since the device changes its output force with the square of the impact speed. Hence most adjustable shocks have a limited operating velocity range, usually on the order of 20 to 130 in/sec. This means that the adjustment is capable of varying the orifice area enough to obtain maximum capacity anywhere over the noted speed range. Impacts outside this range usually require a custom orificed shock absorber.

The Fluidic Control Metering System offers a unique variation of the adjustable type configuration known as a self-adjusting absorber. The self-adjusting Fluidic Control shock will actually vary its output force, energy capacity, and stroke with respect to impact mass and velocity, without any manual adjustment. This effect is obtained by adding an inertia type valve in a series-parallel combination with the Fluidic Control piston head and a pressure responsive shunt valve. When the shock is impacted and starts to go through its rise time period, the inertia valve will respond to the slight reduction in velocity of the impact mass which occurs due to the energy absorbed during the rise time. The valve will then control the amount of fluid regulated through both the fluidic orifice passages and the pressure responsive valved shunt. By using a pressure responsive valve across the shunt orifices, efficiency can be maintained. Because the inertia valve senses the effect of an output force acting upon the impacting mass, the valve will respond to drive force inputs by increasing its output force. This gives near ideal response for industrial applications where accurate positioning without violent bottoming is required. If the impact weight or velocity changes, the valving system will respond and change the shock absorber response, even if the impact conditions vary with each cycle. The Fluidic Control self-adjusting shock absorber has an operating velocity range which is more restricted than manually

adjustable types, usually from 10-70 in/sec. This range is suitable for most industrial applications.

In general, the highest disadvantage to any adjustable shock absorber is its high cost relative to a custom orificed type of device. The user can save large sums of money if his applications are repetitive enough in impact weight and speeds to use a non-adjustable style of absorber. One must also include the cost of the workers who must go about the plant adjusting the manually adjustable shocks as impact conditions change.

## **F. SPECIALIZED SHOCK ABSORBERS.**

Many segments of industry do not use the basic standard types of shock absorbers previously discussed, due to cost or application considerations. Several of these more unusual designs will be discussed.

1. *Pressure Responsive and Spool Valve Metering Systems* Shock absorbers using this type of metering have a more or less constant response force, and hence a varying stroke, over a range of impact velocities. Whether the shock is impacted at 1 in/sec. or 200 in/sec., it will still put out the same impact force. These types of shocks are occasionally built for applications where the input energy is mostly a drive force with little kinetic energy.
2. *Snubber Type Metering Systems* In a snubber type metering system, valves are used across a shunt orifice to yield a fixed orifice type of metering at low speeds. Above a certain preset speed range, the valve will totally close off, locking the shock absorber solid. The only response after the valve closes comes from the slight compressibility of the working fluid. Snubbers are fairly common in applications subject to seismic shock where it is desired to keep one object from hitting another. The biggest problem with snubbers is that after an impact occurs to lock the valving, the snubber will keep increasing its force until it, or the object it is supposed to protect, is destroyed. This cannot occur if the snubber is designed right, but for seismic applications, one must totally define what variety of earthquake, bomb blast, etc., will cause the snubber to operate, and this is exceedingly difficult to do. Eventually the snubber may well become extinct, being replaced by more conventional shock absorber designs.
3. *Shock Absorber Metering with Special Fluids* As has been mentioned previously, metering tube, metering pin, and fixed orifice shock absorbers are unable to respond to drive forces without a drastic loss in efficiency. Some manufacturers are offering shocks with high-viscosity or so called non-Newtonian fluids in an attempt to counter drive forces. These fluids yield higher output forces than theory predicts at low velocities, due to increased viscous drag as the fluid flows through the shock's orifices. The non-Newtonian fluids are particularly interesting because their viscous drag is so great at low velocity that the fluid practically "glues" itself to the orifice. So far, experimentation with the special fluids has been only marginally successful for several reasons, including incompatibility of the fluids with seals, chemical breakdown of the fluids and possible health hazards with some of the more exotic fluids whose effects on humans are largely undetermined.

4. *Mill Type Shock Absorbers* The mill type shock absorber may be impacted once a minute, or once every 10 years, and when it is used there often is someone's life depending upon the performance of the shock. Because of these basic requirements, normal industrial products are not suitable for mill usage because neither their reliability nor their energy capacity is high enough.

Mill type shocks are generally well over-designed with generous safety factors on all parts. Piston rods are usually protected from the environment by non-breathing bellows, steel guide sleeves, or both. Eliminating the exposed rod usually eliminates most requirements for maintenance. All seal materials used must be compatible with the working fluid to the extent that no deterioration will occur for at least 10 years of service. Because of the long service life, the user of the mill buffer generally looks for a shock absorber manufacturer with designs that have remained unchanged for several years, and have a proven record in mill service.

For low energy applications, an acceptable alternative to the mill type buffer is to utilize a standard industrial shock absorber running at no more than ½ of its catalog rated energy capacity. The resulting loading yields a 2:1 safety factor on all internal parts, in addition to whatever factor the manufacturer has used. The shock should be equipped with oversize reset springs and a non-breathing type of metal or rubber boot to protect the rod and insure reset after impact under adverse conditions.

## **SHOCK ABSORBER RESET SYSTEMS**

During an impact it is the job of the metering system to absorb the energy associated with the input energy to the shock. It is the job of the reset system to get the shock absorber back in position for the next impact. Most devices available today utilize one or more of the following restoration means:

- A. The Coil Spring
- B. The Low Pressure Gas Spring
- C. The High Pressure Gas Spring
- D. The Liquid Spring

The above will be discussed and compared as to their effectiveness in the shock absorber.

### **A. COIL SPRING RESET**

The coil spring is the most popular type of shock absorber reset in service today. Coil springs can be mounted either inside or outside of the shock; inside being usually preferred due to safety considerations. Coil spring reset has the advantage of being inexpensive and reliable. Its only disadvantage is that the reset force of most coil spring reset shock absorbers is marginal for adverse temperature and icing conditions. Under these conditions the shock will often stick in the compressed position since the coil spring will not have adequate force to reset against the ice buildup and additional seal friction caused by low temperature.

## **B. LOW PRESSURE GAS RESET**

This type of reset uses external plumbing to connect the shock absorber to a shop air supply, either directly or via an accumulator. This system has the advantage of being initiated on demand by utilizing control valves to delay reset. Thus, the shock absorber can be impacted and will stay fully compressed until reset is desired. The disadvantage of this type of restoration is the cost and complexity of the plumbing involved. Because of the large volume of fluid used, this type of reset lends itself to extreme high cyclic rate applications, since the hot oil from the shock can be cycled through a heat exchanger and keep the shock absorber from destroying itself.

## **C. HIGH PRESSURE GAS RESET**

This method of reset is similar to the low pressure system, except that a small chamber inside the shock is used for the accumulator. Because of the smaller gas volume, much higher pressures are generated, but this system has the advantage of being self-contained.

Care must be taken with this type of design in that all seals must be of the high pressure variety. In a typical case of a gas compressed to 5,000 psi, the volume of the gas is about .03% of its volume at atmospheric pressure. This means that should a leak develop in a fluid seal, all of the fluid will be forced out of the unit rendering the shock inoperative. In addition, should the shock be physically damaged, it would present a severe safety hazard due to possible fragmentation explosion. In shocks of this style, generous safety factors are normally used on the metallic parts, because of the potential hazards of high pressure gas. With the advent of the government OSHA safety code, shock absorbers with high pressure gas reset are rarely used in industry.

## **D. LIQUID SPRING RESET**

This method of reset uses the properties of the compressible oils discussed earlier. In a liquid spring shock absorber, the working fluid is compressed by the piston rod of the shock at the same time it is being orificed by the motion of the piston head. This type of reset yields an exceedingly simple shock absorber, with very high reset forces. The design is ideal for applications where large amounts of drive energy must be positively counterbalanced. Custom seals, with very high pressure ratings are required, as fluid pressures of up to 20,000 psi are often used. Since the oil is usually compressed no more than 10% by volume, no explosion hazards exist, since the fluid will merely flow out should physical damage occur to the shock absorber. This type of reset is often used in conjunction with a metering system that acts in both the compression and reset directions. Orificing in the reset mode enables the shock to gently return to its initial position without rebound. This concept works exceedingly well in applications subject to severe icing conditions.

Liquid spring shocks are also seeing successful service in industry as suspension struts, replacing coil, leaf, and rubber spring suspension systems.

## SELECTION OF SHOCK ABSORBERS

Choosing a shock absorber for any normal application is not at all difficult, provided that one can adequately define what the energy capacity requirements are. If one does not wish to “grind out” a shock size via sizing formulas, consult the manufacturer of your choice. For most applications, a size can be established over the telephone. The information presented in this section will offer both the sizing formulas usually required and the qualitative datum required to make the correct choice.

### A. DETERMINE IF A HYDRAULIC SHOCK ABSORBER IS NEEDED

Two basic rules can be used to determine if a given application has enough energy to warrant a hydraulic shock. In general, a hydraulic shock absorber is required if either of the following conditions exist:

1. Structural damage or excessive noise is present in an existing system which can be attributed to the reaction of a weight moving at a speed, with a drive force.
2. A calculated energy of at least 50 in-lb exists in a system with no provisions for removing that energy from the system, and the calculated energy in the units of in-lb. is greater than 1/10 the impacting weight measured in the units of lbs.

With respect to rule 1 above, if structural damage or noise exists in a system which is not due to the action of a weight moving at a definite speed, then a vibration isolator is probably needed, rather than a hydraulic shock absorber.

With respect to rule 2 above, if the energy to be absorbed is less than 100 in-lb., it is often more economical to utilize a block of rubber, a spring, etc., to eliminate the problem. If the calculated energy (in-lb) is less than 1/10 the impacting weight (lb), the structural spring rate of the weight is usually able to store the energy involved. For example, a weight of 10,000 lb. is usually able to store 1,000 in-lb. without any need for a shock absorbing device. The only time this rule would not apply is when very fragile impact weights are involved. Again, using the 10,000 lb. impact weight as an example, an energy of more than 1,000 in-lb. would probably require a hydraulic shock absorber.

### B. THE COST OF A HYDRAULIC SHOCK ABSORBER

The cost of a shock absorber varies with the energy capacity, and the quantity required.

In general, using 2001 prices one can roughly expect the following prices to result for a purchase of 2-4 pieces of an industrial shock absorber.

1. 500 in-lb. shock absorber. = \$65 each
2. 1,000 in-lb. shock absorber = \$95 each

3. 10,000 in-lb. shock absorber = \$325 each
4. 100,000 in-lb. shock absorber = \$630 each
5. 1,000,000 in-lb. shock absorber = \$1,875 each
6. 10,000,000 in-lb. shock absorber = \$13,000 each

Prices will vary, of course, with optional equipment, mounting styles, etc. For larger quantity purchases, expect a discount of around 10% for 25 pc., 20% for 100 pc., and 30% for 1,000 pc.

### C. SELECTING THE CORRECT DIAMETER AND STROKE

A given energy capacity can result in several choices of shock absorber diameter and stroke. Since energy is the integral of force over increments of stroke, a large diameter device with a short stroke can have the same capacity as a small diameter shock with a long stroke.

For example, a capacity of 250,000 in-lb. can be obtained with the following sizes of shock absorbers from the current Taylor Devices catalog:

Model	Diameter (in.)	Stroke (in.)	Output Force (lb.)	Capacity (in-lb.)
3 x 8	3	8	35,000	252,000
4 x 6	4	6	50,000	270,000
5 x 4	5	4	85,000	306,000
6 x 2	6	2	150,000	270,000

Any of these sizes are perfectly adequate from a capacity basis, but each size has its advantages and disadvantages:

1. The 3 x 8 is the least expensive, the 6 x 2 is the most expensive.
2. The 3 x 8 has the lowest reaction force, the 6 x 2 puts out the highest force.
3. The 6 x 2 is the shortest, and hence takes less effort to package.
4. The 6 x 2 can withstand the most abuse, and is virtually impervious to scrubbing and sideload damage.
5. The 6 x 2 will give the longest cyclic life, since its short stroke yields the least number of square inches of piston rod circumferential area passing through its seals each cycle.
6. The 3 x 8 is the lightest of the group.
7. The 4 x 6 and 5 x 4 offer qualities in between the 3 x 8 and 6 x 2.

By comparing the qualities noted in 1-7 above against selling price and the requirements of a given application, one can usually make the best size selection.

Note that the sizes listed above do not make any mention as to “bore” size. To compare shock absorbers by bore size is extremely difficult because of different designs and internal pressure ratings existing among the various manufacturers. The term “bore size” is more properly applied to hydraulic cylinders than to shock absorbers, since the hydraulic cylinder must be matched to the external pump source that will actuate it. The shock absorber’s output is generated by an internal pressure acting over the piston head area, hence bore size alone is not an adequate method of rating shock absorbers, since various manufacturers use a wide range of operating pressures. When comparing the different products, one should be concerned with energy capacity, stroke, and output force (efficiency related), as it is these properties that determine whether a shock will operate properly in a given application.

#### D. SIZING CALCULATIONS

The formulae presented in this section are to be used only with the units listed below:

- W = Weight (lbs.)
- V = Linear velocity (ft/sec.)
- V<sub>R</sub> = Rotational velocity (radians/sec.)
- F = Shock absorber output force (lb.)
- F<sub>D</sub> = External drive force
- H = Vertical height (in.)
- S = Shock absorber stroke (in.)
- I = Moment of Inertia (lb-ft.sec<sup>2</sup>)
- KE = Kinetic energy (in-lb.)
- μ = Shock absorber efficiency (expressed as a fraction)

##### 1. Solving for kinetic energy:

Kinetic energy normally occurs in 3 forms, from linear, rotary, or free falling (vertical) motion.

###### a. For linear motion:

$$KE = .1865 W \cdot V^2 \text{ (in-lb.)}$$

###### b. For rotary motion:

$$KE = 6 \cdot I V_R^2 \text{ (in-lb.)}$$

###### c. For free falling (vertical) motion:

$$KE = W (H + S) \text{ (in-lb.)}$$

2. Solving for external drive energy: Calculating drive energy requires that one know what the drive force is at the point where the shock absorber is mounted.

$$\text{Drive energy} = F_D \cdot S \text{ (in-lb.)}$$

3. Solving for shock absorber energy capacity

For any given application, the total shock absorber capacity is the sum of the energy inputs to the shock. Therefore:

$$\text{Shock capacity} = \text{KE} + \text{drive energy}$$

After obtaining the shock absorber capacity, consult a manufacturer's catalog for the various combinations of diameter and stroke available for your application. For applications involving rotary motion, it is recommended that a stroke be used such, that the stopping angle is less than 5°.

4. Solving for shock absorber deceleration rate, without drive force:

- a. For linear motion:

$$\text{Deceleration rate (G's)} = \frac{F}{W} = \frac{.1865V^2}{S \cdot \mu}$$

Deceleration rates determine how fast the shock absorber will stop the impacting weight. In general, for relatively noise-free industrial applications, a deceleration rate of less than 2 G's is desirable. When drive forces are present, the shock absorber must resist the drive force with a portion of its output force equal to the drive force. Hence, the deceleration rate with drive will be lower than that without.

5. Solving for shock absorber deceleration time:

$$\text{Deceleration time (sec)} = \frac{S}{6 \cdot V \cdot \mu}$$

Deceleration time is rarely of much use in sizing shock absorbers unless the stroke is quite large. For example:

A 2 inch stroke shock, with 70% efficiency, being hit at 2 ft/sec., has a deceleration time of:

$$\text{Deceleration time} = \frac{S}{6 \cdot V \cdot \mu} = \frac{2}{6 \times 2 \times .7} = .24 \text{ sec.}$$



Since most industrial applications cycle at between 3 and 10 cycles per minute, the .24 sec. deceleration time is of no real consequence.

## **CONCLUSIONS**

It is hoped that this paper will give the reader a better understanding of how to select and use shock absorbers in industrial usage. It has been shown that various types of shock absorber designs are available, each of which performs best in specific types of applications. The formulas presented should give the reader at least a rudimentary knowledge of how to select a size for a specific job. There are many aspects of selection criteria and equations that have not been treated here, simple because they are beyond the scope of this paper. If the reader has any further questions concerning the topics discussed herein, the author would welcome the inquiry.